

CPCI7203

3U Air and Conduction Cooled Processor Board

■ Embedded Computing for Business-Critical Continuity™

Ideal for high performance applications in space-constrained applications

- Intel Core i7 integrated dual-core processor (1.06 GHz ULV or 2.0 GHz LV)
- Up to 8GB ECC-protected DDR3-800/1066 (soldered)
- 256KB non-volatile F-RAM
- Mobile Intel® 5 Series chipset: Ibex Peak-M PCH
- VGA interface
- Two on-board Gigabit Ethernet interfaces
- Two USB 2.0 (front air cooled)
- Four USB 2.0 ports (rear)
- Four PCI Express interfaces
- Two SATA interfaces
- One UART port
- Full PICMG 2.1, R2.0 Hot Swap specification compliance
- PICMG 2.9 System Management specification support
- PICMG 2.30 CompactPCI® PlusIO compatible pinouts for J2 USB, SATA and PCI Express
- Air and conduction cooled
- Extended temperature range (-40 °C to +85 °C)
- Optional rear transition module

The Emerson Network Power CPCI7203 single-board computer (SBC) uses the Intel® Core™ i7 integrated dual-core processor in the 3U form factor for high performance applications in space-constrained applications. Emerson's leading edge thermal and rugged solution makes the CPCI7203 ideal for harsh environments. On-board memory includes up to 8GB soldered ECC DDR3 memory and the air cooled variants also support 256KB non-volatile Ferroelectric Random Access memory (F-RAM) and 4GB MicroSD flash. Connectivity is optimized for maximum throughput and flexibility. The air cooled variants have two Gigabit Ethernet ports, two USB 2.0 ports, and one VGA on the front panel. Rear IO includes one serial port, two SATA ports and four PCI interfaces to the rear. Conduction cooled variants also provide rear VGA. The Trusted Platform Module (TPM) enhances data security and encryption capabilities. The CPCI7203 supports a range of operating system and software options including Wind River VxWorks, Fedora Linux and Microsoft® Windows®.

The CPCI7203 is a low-power, high-performance SBC that offers full hot swap compliance per PICMG® 2.1, supports the PICMG 2.9 System Management and provides compatible pinouts for PICMG 2.30 CompactPCI PlusIO.

The Intelligent Platform Management Interface (IPMI) supports the PICMG 2.9 specification; the blade can host the Baseboard Management Controller (BMC) or act as a Peripheral Management controller (PM) node.

The CPCI7203 board is a superior choice for a wide range of industrial, medical and military/aerospace applications, such as railway control, factory automation, semiconductor processing, robotics, image processing, vetronics, VoIP and first responder.



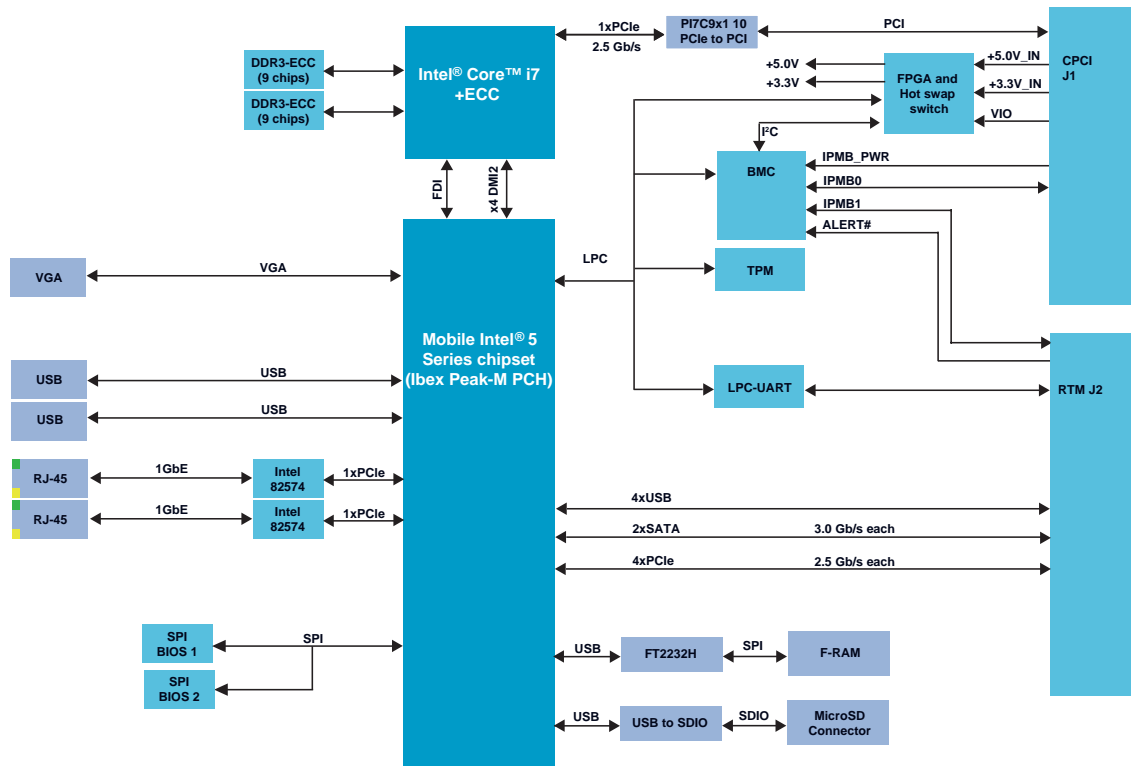

EMERSON™
Network Power

CPCI7203 Block Diagram (Air Cooled)

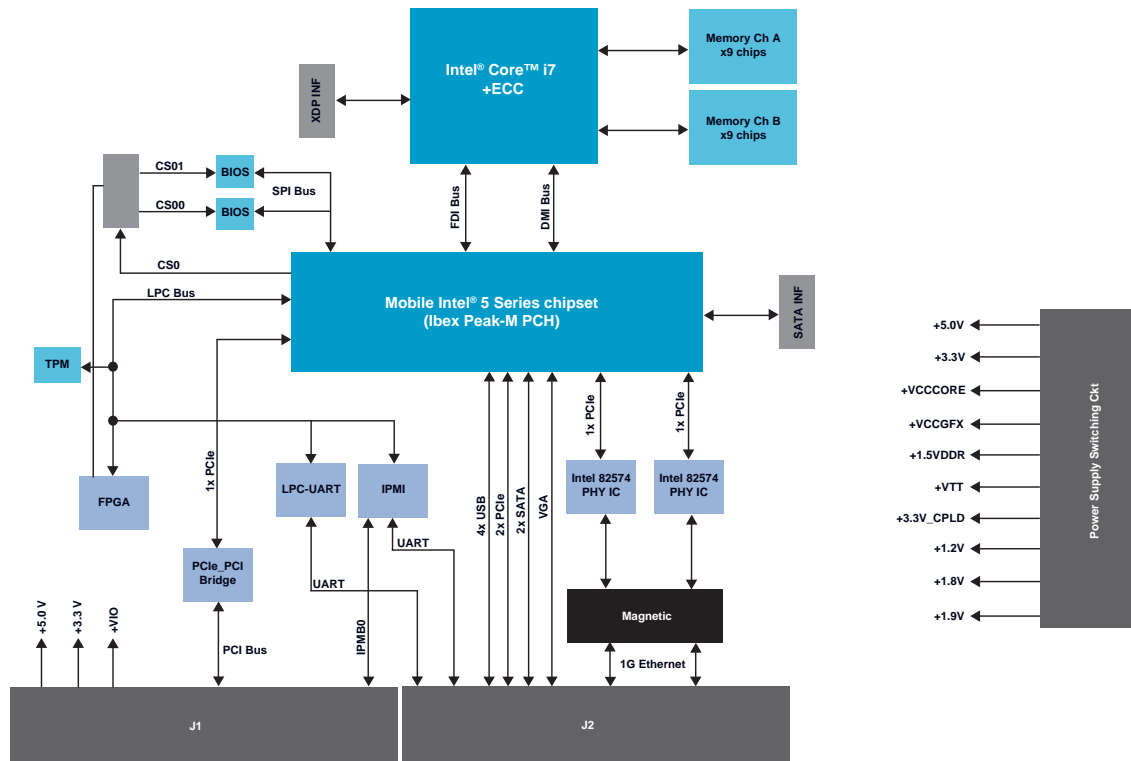

CPCI7203 Block Diagram (Conduction Cooled)



Specifications

HARDWARE PROCESSOR/CHIPSET

- 1.06 or 2.0 GHz Intel® Core™ i7 dual-core processor
- 2MB or 4MB on-chip L2 cache; 32KB L1 cache
- Intel® Ibex Peak-M PCH
- Dual DDR3-800/1066 memory controller
- 1x lane PCI Express
- x4 DMI Interface to PCH
- No frontside bus, north bridge is integrated in the processor

MEMORY

- Dual channel 17.0GB/s memory architecture
- 1GB, 2GB, 4GB or 8GB ECC-protected DDR3-800/1066 with ECC
 - ▲ Conduction cooled: 4GB or 8GB

USER FLASH MEMORY (AIR COOLED ONLY)

- 4GB MicroSD flash module
- 256KB F-RAM (NVRAM)

BOOT FLASH MEMORY

- 64MB SPI flash
- Support for crisis recovery

STORAGE

- Optional 128GB solid state hard drive (conduction cooled only)

COMPACTPCI INTERFACE

- Universal CompactPCI Bus
- System- and peripheral-slot capability (32-bit/66 MHz)

I/O CAPABILITIES (AIR COOLED)

- Two Gigabit Ethernet interfaces
- IPMI 1.5 remote platform and system management support (PICMG 2.9)
- VGA (front)
- Four USB 2.0 ports (two front/two rear)
- Four PCI Express interfaces (rear)
- One UART port (rear)
- Two SATA interfaces (rear)

I/O CAPABILITIES (CONDUCTION COOLED)

- Two 1000B-T interfaces
- IPMI 1.5 remote platform and system management support (PICMG 2.9)
- VGA
- Four USB 2.0 interfaces
- Four PCI Express interfaces
- One UART
- Two SATA interfaces

OPTIONAL TRANSITION MODULES

- PCI Express, USB 2.0, UART, SATA, Reset
- 1000BASE-T, USB 2.0 Type A, RS-232, VGA, SATA port headers, dual port USB header, DIP switch for SSD erase (conduction cooled)

OTHER FEATURES

- Trusted Platform Module (TPM)
- Watchdog timer
- POST codes, status and user LEDs
- Reset switch
- Locking ejector handles
- Power-up ramping and in-rush current protection
- Hot swap support (PICMG 2.1, R2.0)

POWER REQUIREMENTS

- Maximum for 1.06 GHz, 1GB memory variant
 - ▲ 3.3V 2A 6.6W
 - ▲ 5.0V 7.5A 37.5W
 - ▲ 44W (maximum total power dissipation)
- Maximum for 2.06 GHz, 2GB memory variant
 - ▲ 3.3V 2A 6.6W
 - ▲ 5.0V 10A 50W
 - ▲ 57W (maximum total power dissipation)
- Maximum for 2.0 GHz, 4GB memory variant
 - ▲ 3.3V 2A 6.6W
 - ▲ 5.0V 10A 50W
 - ▲ 57W (maximum total power dissipation)
- Maximum for 2.0 GHz (CPCI7203), 8GB memory variant
 - ▲ 3.3V 2A 6.6W
 - ▲ 5.0V 10.68A 53.4W
 - ▲ 60W (maximum total power dissipation)

ELECTROMAGNETIC COMPATIBILITY (EMC)

- Intended for use in systems meeting the following regulations:
 - ▲ U.S.: FCC Part 15, Subpart B, Class A (non-residential)
 - ▲ Canada: ICES-003, Class A (non-residential)
- Emerson board products are tested in a representative system to the following standards:
 - ▲ CE Mark per European EMC Directive 89/336/EEC with Amendments
 - ▲ Emissions: EN55022 Class B; Immunity: EN55024

MTBF

Calculated per Telcordia SR-332, Issue 1 and based on a ground fixed, controlled environment assuming an inlet air temperature of between 0° C and 50° C. 200,000 hours

DOCUMENTATION

- Installation Guide and Technical Reference Manual
- Hardware Release Notes
- UEFI BIOS Release Notes
- Linux Installation and Programmer's Guides

Environmental Requirements				
Ruggedization Level ³	ENP1	ENP2	ENP3	ENP4
Cooling Method	Forced Air	Forced Air	Conduction	Conduction
Operating Temperature	0 °C to +55 °C	-40 °C to +71 °C	-40 °C to +71 °C	-40 °C to +85 °C
Storage Temperature	-40 °C to +85 °C	-50 °C to +100 °C	-50 °C to +100 °C	-50 °C to +125 °C
Vibration Sine (10min/axis)	1G, 5 to 2000 Hz	5G, 15 to 2000 Hz	10G, 15 to 2000 Hz	10G, 15 to 2000 Hz
Vibration Random (1hr/axis)	.002g ² /Hz, 15 to 2000 Hz	.04g ² /Hz, 15 to 2000 Hz (8GRMS) ¹	0.1g ² /Hz, 15 to 2000 Hz (12GRMS) ²	0.1g ² /Hz, 15 to 2000 Hz (12GRMS) ²
Shock	20g/11mS	30g/11mS	40g/11mS	40g/11mS
Humidity	to 95% RH	to 100% RH	to 100% RH	to 100% RH
Conformal Coating	No	Option (Acrylic)	Option (Acrylic)	Option (Acrylic)
Note 1: Flat 15-1000 Hz, -6db/octave 1000-2000 Hz [MIL-STD 810F Figure 514.5C-17]				
Note 2: +3db/octave 15-300 Hz, Flat .1g ² 300-1000 Hz, -6db/octave 1000-2000 Hz [MIL-STD 810F Figure 514.5C-8]				
Note 3: Component and/or assembly screening shall be employed to satisfy feature/functional requirement (where feasible) when components are not available that meet ruggedization level requirements.				

Ordering Information	
Part Number	Description
CPCI7203-10-1GB	3U CPCI Intel Core i7 1.06 GHz, 1GB DDR3, ENP1
CPCI7203-20-2GB	3U CPCI Intel Core i7 2.0 GHz, 2GB DDR3, ENP1
CPCI7203-20-4GB	3U CPCI Intel Core i7 2.0 GHz, 4GB DDR3, ENP1
CPCI7203-20-8GB	3U CPCI Intel Core i7 2.0 GHz, 8GB DDR3, ENP1
CPCI-7203-RTM	RTM, ENP1
CPCI7203-22044	3U CPCI Intel Core i7 2.0 GHz, 4GB DDR3, ENP4
CPCI7203-22084	3U CPCI Intel Core i7 2.0 GHz, 8GB DDR3, ENP4
CPCI7203-22044HD	3U CPCI Intel Core i7 2.0 GHz, 4GB DDR3, ENP4 with SDD
CPCI7203-22084HD	3U CPCI Intel Core i7 2.0 GHz, 8GB DDR3, ENP4 with SSD
CPCI7203-RTM4	RTM, ENP4













SOLUTION SERVICES

Emerson Network Power provides a portfolio of solution services optimized to meet your needs throughout the product lifecycle. Design services help speed time-to-market. Deployment services include global 24x7 technical support. Renewal services enable product longevity and technology refresh.

PICMG and CompactPCI are registered trademarks of the PICMG. Intel and Core™, are trademarks or registered trademarks of Intel Corporation or its subsidiaries in the U.S. and other countries. All other product or service names are the property of their respective owners.

This document identifies products, their specifications, and their characteristics, which may be suitable for certain applications. It does not constitute an offer to sell or a commitment of present or future availability, and should not be relied upon to state the terms and conditions, including warranties and disclaimers thereof, on which Emerson Network Power may sell products. A prospective buyer should exercise its own independent judgment to confirm the suitability of the products for particular applications. Emerson Network Power reserves the right to make changes, without notice, to any products or information herein which will, in its sole discretion, improve reliability, function, or design. Emerson Network Power does not assume any liability arising out of the application or use of any product or circuit described herein; neither does it convey any license under its patent or other intellectual property rights or under others. This disclaimer extends to any prospective buyer, and it includes Emerson Network Power's licensee, licensee's transferees, and licensee's customers and users. Availability of some of the products and services described herein may be restricted in some locations.

Emerson Network Power.
The global leader in enabling
Business-Critical Continuity™.

-  AC Power
-  Embedded Power
-  Precision Cooling
-  Connectivity
-  Infrastructure Management & Monitoring
-  Racks & Integrated Cabinets
-  DC Power
-  Outside Plant
-  Services
-  Embedded Computing
-  Power Switching & Controls
-  Surge Protection

Emerson Network Power

Offices: Tempe, AZ U.S.A. 1 800 759 1107 or +1 602 438 5720
 Paris, France +33 1 60 92 31 20 • Munich, Germany +44 1509 236490 • Tel Aviv, Israel +972 99560361
 Hong Kong +852 2176 3540 • Shanghai, China +86 21 3395 0289 • Tokyo, Japan +81 3 5403 2730 • Seoul, Korea +82 2 3483 1500

EmersonNetworkPower.com/EmbeddedComputing

Emerson, Business-Critical Continuity and Emerson Network Power are trademarks of Emerson Electric Co. or one of its affiliated companies. ©2011 Emerson Electric Co.