

TPMC863 4 Channel High Speed Synch/Asynch Serial Interface

Application Information

The TPMC863 is a standard single-width 32 bit PMC with four high speed serial data communication channels.

The TPMC863 is the successor of the discontinued TPMC862, providing similar functionality and full connector and pin-out compatibility.

The serial communication controller is implemented in FPGA logic, along with the bus master capable PCI interface, guaranteeing long term availability and having the option to implement additional functions in the future.

Each channel has a receive and a transmit FIFO of 512 long words (32 bit) per channel for high data throughput.

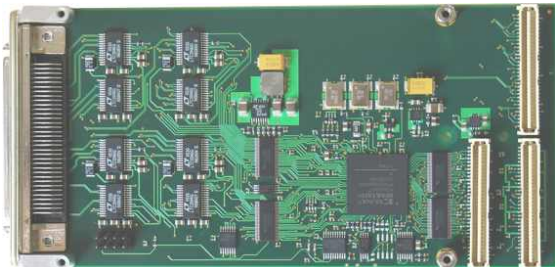

Data transfer on the PCI bus is handled via TPMC863 initiated DMA cycles with minimum host/CPU intervention. Several serial communication protocols are supported by each channel, such as asynchronous, isochronous, synchronous and HDLC mode.

A 14.7456 MHz oscillator provides standard asynchronous baud rates. An additional 24 MHz oscillator is provided for other baud rates. A 10 MHz oscillator is used for the synchronous baud rate of 10 Mbit/s.

Each channel also provides various interrupt sources, generated on INTA. The interrupt sources can be enabled or disabled individually.

Multiprotocol transceivers are used for the line interface. The physical interface is selectable by software, individually for each channel as EIA-232, EIA-422, EIA-449, EIA-530, EIA-530A, V.35, V.36 or X.21.

The following signals are provided by the TPMC863 for each channel at the front and rear-I/O connectors: Receive Data (RxD +/-), Transmit Data (TxD +/-), Receive Clock (RxC +/-), Transmit Clock (TxC +/-), Ready-To-Send (RTS +/-), Clear-To-Send (CTS +/-), Carrier-Detect (CD +/-) and GND. Additionally serial channel 3 provides Data-Set-Ready (DSR3 +/-) and Data-Terminal-Ready (DTR3 +/-) at the front I/O connector.

The TPMC863 provides front panel I/O via an HD68 SCSI-3 type connector and rear I/O via P14.

For First-Time-Buyers the engineering documentation TPMC863-ED is recommended. The engineering documentation includes TPMC863-DOC, schematics and data sheets of TPMC863 devices.

Technical Information

- Standard single-width 32 bit PMC module conforming to IEEE P1386.1
- PCI 2.1 compliant master/slave interface
- 3.3V and 5V PCI Signaling Voltage
- Board size: 147 mm x 74 mm
- Four high speed synchronous/asynchronous serial interfaces
- Support of RxD, TxD, RxC, TxC, RTS, CTS, CD and GND on HD68 front connector, parallel to rear connector P14; DTR3 and DSR3 at front I/O only
- Physical interface (individually programmable per channel): EIA-232, EIA-422, EIA-449, EIA-530, EIA-530A, V.35, V.36 and X.21
- Maximum data rate: 10 Mbit/s (synchronous), 2 Mbit/s (asynchronous), internal or external provided clock
- EIA-232: up to 115.2 kbit/s
- Temperature range: -40°C to +85°C

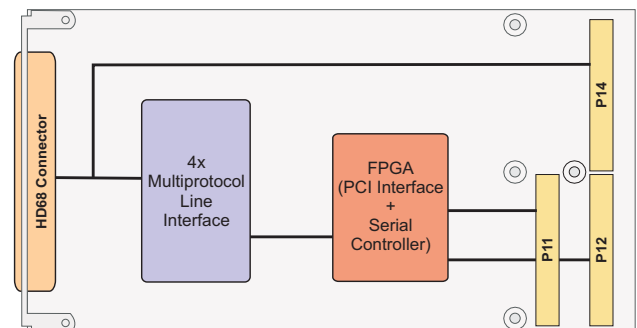

Order Information

RoHS Compliant

TPMC863-10R 4 Channel High Speed Synch/Asynch
Serial Interface

None RoHS Compliant

TPMC863-10 None RoHS compliant version of
TPMC863-10R

Documentation

TPMC863-DOC User Manual

TPMC863-ED Engineering Documentation
(TPMC863-DOC, Schematics,
Assembly Drawing, Data Sheets)

Software

TDRV009-SW-25 Integrity Software Support

TDRV009-SW-42 VxWorks Software Support
(Legacy and VxBus-Enabled Software
Support)

TDRV009-SW-65 Windows XP/XPE2000 Software
Support

TDRV009-SW-72 LynxOS Software Support

TDRV009-SW-82 LiNIX Software Support

TDRV009-SW-95 QNX 6 Software Support

For other operating systems please contact TEWS.

Related Products

TA304 Cable Kit for modules with HD68
connector

TPIM005 PIM I/O Module with HD68 SCSI-3
type connector