

**NuIPC**  
**cPCI-8217 series**  
**3U CompactPCI VGA/LCD Display Module**  
**with SM721 Controller**  
**User's Guide**



Recycled Paper



©Copyright 2001 ADLINK Technology Inc.

All Rights Reserved.

Manual Rev. 1.00: Sep 10, 2001

Part No. 50-15003-100

The information in this document is subject to change without prior notice in order to improve reliability, design and function and does not represent a commitment on the part of the manufacturer.

In no event will the manufacturer be liable for direct, indirect, special, incidental, or consequential damages arising out of the use or inability to use the product or documentation, even if advised of the possibility of such damages.

This document contains proprietary information protected by copyright. All rights are reserved. No part of this manual may be reproduced by any mechanical, electronic, or other means in any form without prior written permission of the manufacturer.

### **Trademarks**

NuIPC is a registered trademark of ADLINK Technology Inc.

Other product names mentioned herein are used for identification purposes only and may be trademarks and/or registered trademarks of their respective companies.

# Getting service from ADLINK

- ◆ Customer Satisfaction is always the most important thing for ADLINK Technology Inc. If you need any help or service, please contact us and get it.

ADLINK Technology Inc.			
Web Site	http://www.adlink.com.tw http://www.adlinktechnology.com		
Sales & Service	service@adlink.comtw		
Technical Support	NuDAQ	nudaq@adlink.com.tw	
	NuDAM	nudam@adlink.com.tw	
	NuIPC	nuipc@adlink.com.tw	
	NuPRO	nupro@adlink.com.tw	
TEL	+886-2-82265877	FAX	+886-2-82265717
Address	9F, No. 166, Jian Yi Road, Chungho City, Taipei, 235 Taiwan, R.O.C.		

- ◆ Please inform or FAX us of your detailed information for a prompt, satisfactory and constant service.

Detailed Company Information			
Company/Organization			
Contact Person			
E-mail Address			
Address			
Country			
TEL		FAX	
Web Site			
Questions			
Product Model			
Environment to Use	<input type="checkbox"/> OS _____ <input type="checkbox"/> Computer Brand : _____ <input type="checkbox"/> M/B : <span style="float: right;"><input type="checkbox"/>CPU :</span> <input type="checkbox"/> Chipset : <span style="float: right;"><input type="checkbox"/>BIOS :</span> <input type="checkbox"/> Video Card : <input type="checkbox"/> Network Interface Card : <input type="checkbox"/> Other :		
Challenge Description			
Suggestions to ADLINK			

# Table of Contents

<b>Chapter 1 Introduction</b> .....	<b>1</b>
1.1 Checklist.....	1
1.2 Product description .....	3
1.3 Features .....	3
1.4 Specifications .....	4
1.5 Block diagram .....	7
<b>Chapter 2 Hardware Installation</b> .....	<b>8</b>
2.1 Jumpers and switches on the cPCI-8217.....	10
2.1.1 JP1&JP2: LCD positioning selection.....	11
2.1.2 JP3: LCD VDD selection.....	11
2.1.3 S1: LCD On/Off Toggle switch.....	11
2.1.4 S2: LCD bit# selection .....	12
2.1.5 S3: LCD type and size selection.....	12
2.2 Connectors on the cPCI-8217.....	13
2.2.1 VGA Connector -- CN8.....	14
2.2.2 LCD Back-light Inverter Connector – CN1 and CN5.....	14
2.2.3 LCD Interface Connector – CN3.....	15
2.2.4 CompactPCI Connectors .....	17
2.3 More features on the cPCI-8217 panel.....	19
2.3.1 LCD brightness adjustment knob .....	19
2.3.2 LCD On indicator (Green LED).....	19
2.3.3 LCD power saving indicator (Amber LED).....	19
<b>Chapter 3 Driver Installation</b> .....	<b>20</b>
3.1 VGA Drivers Installation.....	20
3.1.1 Driver Installation on Windows 2000.....	20
3.1.2 Driver Installation on Windows 98 .....	22
3.1.3 Driver Installation on Windows NT.....	23
<b>Product Warranty/Service</b> .....	<b>24</b>



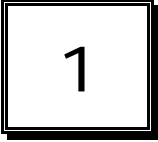

# Introduction

This manual is designed to give you information on the cPCI-8217 series VGA/LCD display module. The topics covered in this chapter are as follows:

- Checklist
- Product description
- Features
- Specifications
- Block diagram

---

## 1.1 Checklist

There are two standard configurations available for cPCI-8217 series module, the information inside this manual can be applied to both models if without specified:

- ◆ cPCI-8217: The 3UCompactPCI VGA/LCD display module without rear I/O support
- ◆ cPCI-8217R: The 3U CompactPCI VGA/LCD display module with rear I/O support

Please check your configurations with your dealer and check that your package is complete and contains the items below. If you discover damaged or missing items, please contact with your dealer.

- ◆ The package for cPCI-8217:
  - The cPCI-8217 module
  - This User's Manual
  - ADLINK CD

- ◆ The package for cPCI-8217R:
  - The cPCI-8217R module
  - The cPCI-R8217 rear I/O transition module
  - This User's Manual
  - ADLINK CD

---

**Note:** The package of cPCI-8217 OEM version (non-standard configuration, functionality or package) may vary according to the different configuration request.

---

---

## 1.2 Product description

The cPCI-8217 series products are 3U CompactPCI form factor VGA and LCD display modules which support CRT monitor and LCD panel display device. cPCI-8217 features SM721 high performance VGA/LCD controller of Silicon Motion Inc. and provides high definition 2D display characteristics with advanced LCD display controls. SM721 controller built-in 4MB video memory provides the capability of driving CRT displays with resolution up to 1600x1200 in 16-bit high color under Windows NT or 2000 environment. It is also capable of driving 24-bit TFT LCD with resolution of 1280x1024 in 24-bit true color.

---

## 1.3 Features

- PICMG 2.0 CompactPCI Specification R2.1 Compliant
- Standard 3U form factor
- PCI bus VGA/LCD controller SMI Lynx3DM SM721, with build-in 4MB VRAM (8MB VRAM available for big quantity OEM project)
- VGA display on front faceplate and 24-bit RGB-TFT LCD connector on the front board
- The 24-bit RGB-TFT LCD interface is also routed to rear I/O transition module (cPCI-8217R only.)
- High performance, 128-bit, single clock cycle 2D drawing engine
- High performance, power managed 3D acceleration engine
- ACPI, VESA DPMS and VESA DDC 2b compliant
- Supports up to 1280x1024 VGA display resolution with 24-bit true color, non-interlaced
- Supports up to 1600x1200 VGA display resolution with 16-bit high color, non-interlaced under WindowsNT (only available when on-board BIOS is configured LCD disable.)
- Dual display and simultaneous display for VGA and LCD (Not available if on-board BIOS is configured LCD disable.)
- RAMDAC Latch-up protection
- LCD brightness adjustable on the front panel
- LCD On/Off switch located on the front panel
- Driver supporting: Windows95/98/ME/NT/2000, Linux, OS/2

---

## 1.4 Specifications

### General CompactPCI Features

- PCI Rev.2.1 compliant
- PICMG 2.0 CompactPCI Rev. 2.1 compliant

### Form Factor

- Standard 3U CompactPCI (board size: 100mm x 160mm)
- 1-slot (4TE/HP, 20.3mm) width

### Bus

- CompactPCI bus in 32-bit/33MHz
- Supports both +5V or +3.3V signaling

### Display Controller and Video Memory

- SMI Lynx3DM SM721
- Build-in 4MB VRAM (8MB VRAM available for big quantity OEM project)

### RAMDAC

- 200MHz, 24-bit RAMDAC
- Supports Latch-up protection

### VGA Interface

- IBM VGA compatible on BIOS, registry and hardware
- ACPI, VESA DPMS and VESA DDC 2b compliant
- Supports up to 1280x1024 VGA display resolution with 24-bit true color, non-interlaced
- Supports up to 1600x1200 VGA display resolution with 16-bit high color, non-interlaced under WindowsNT (only available when on-board BIOS is configured LCD disable.)

### LCD Features

- Supports for 9, 12, 18, 16, 24-bit resolution of TFT or DSTN LCD
- Jumper selectable for LCD display mode which can be up-side-down, left-right-reverse or 180 degree rotated
- DIP switch selectable for LCD resolution which supports 640x480, 800x600, 1024x768 and 1280x1024
- On-board back-light inverter power interfaces provide brightness and back-light inverter power on/off controls

- Dual display and simultaneous display for VGA and LCD (Not available if on-board BIOS is configured LCD disable.)

## BIOS

- On-board VGA/LCD BIOS supports dual display and simultaneous display
- On-board BIOS could be pre-configured as LCD-disable by customer request
- Green Function: ACPI and power saving support.

## Front Panel LEDs and Switch

- LCD output indication (green)
- LCD power saving indication (amber)
- Flush tact switch for LCD on/off switching (only available when the power of back-light inverter is controlled by cPCI-8217)
- Knob for adjusting LCD brightness (only available when the power of back-light inverter is controlled by cPCI-8217)

## Environment

- Operating temperature: 0 to 60°C
- Storage temperature: -20 to 80°C
- Humidity: 5% to 95% non-condensed
- Shock: 15G peak-to-peak, 11ms duration, non-operation
- Vibration:
  - ✓ Non-operation: 1.88Grms, 5-500Hz, each axis
  - ✓ Operation: 0.5Grms, 5-500Hz, each axis, with 2.5" HDD

## Safety Certificate and Test

- CE, FCC
- HALT (temperature and vibration stress)

## Power Consumption

Configurations	+5V	+3.3V	+12V	-12V
CRT & LCD (6.4", 640 × 480 resolution)	150mA	50mA	600mA	0mA
CRT only	150mA	50mA	0mA	0mA

## I/O Connectivity

I/O	Front		Rear (cPCI-8217R)	
	Faceplate	Board	Faceplate	Board
VGA	Y (DB-15)	---	---	---
24-bit TFT-LCD		Y (44-pin)	---	Y (44-pin, J2)

---

## 1.5 Block diagram

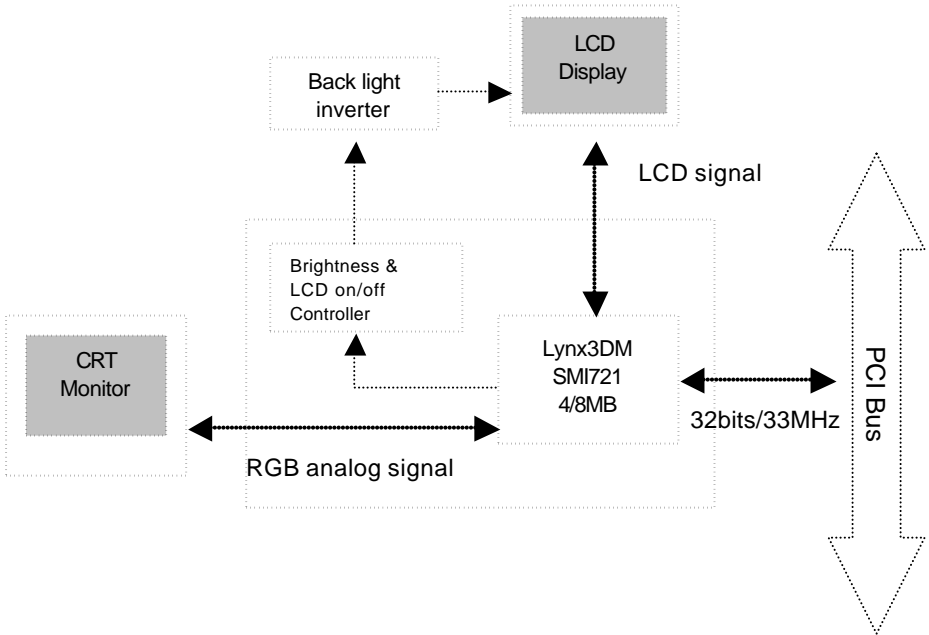

# Hardware Installation

This chapter provides information on how to use the jumpers and connectors on the cPCI-8217 in order to set up a workable system. The topics covered are:

- Jumpers and switches on the cPCI-8217
- Connectors on the cPCI-8217

Jumpers, switches and connectors map of cPCI-8217 board

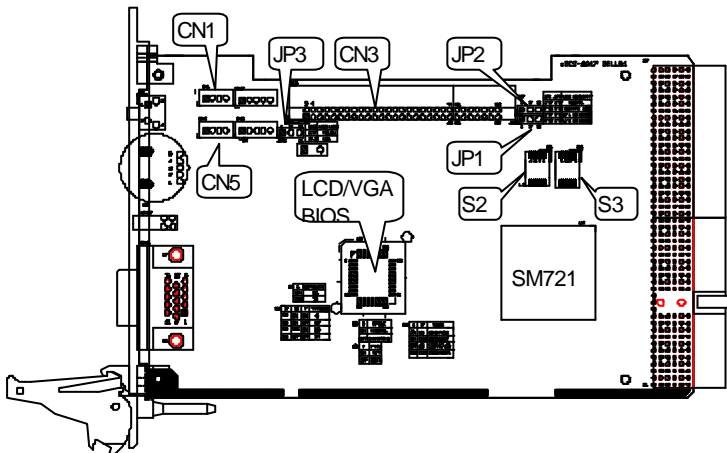

LEDs, switches and connectors map of cPCI-8217 panel

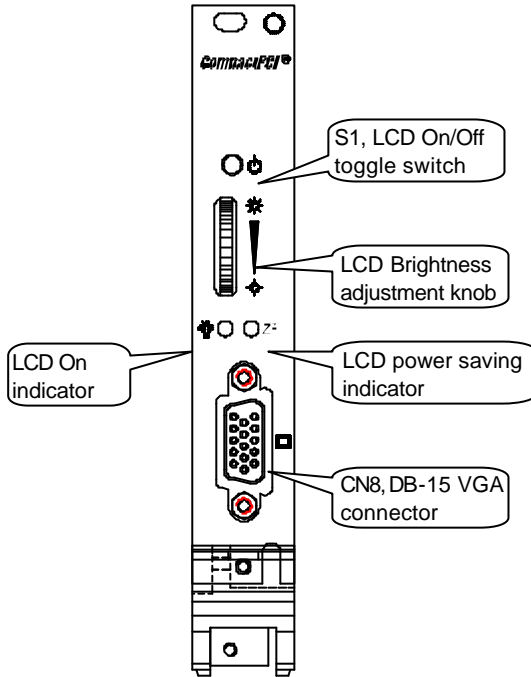

---

## 2.1 Jumpers and switches on the cPCI-8217

The jumpers and switches on the cPCI-8217 allow you to configure your display module according to the needs of your applications. If you have doubts about the best jumper or switch configuration for your needs, contact your dealer or sales representative. The following table lists the jumper connectors on cPCI-8217 and their respective functions.

### *Jumpers on the cPCI-8217*

Jumper	Description
JP1 & JP2	LCD positioning
JP3	LCD VDD selection

### *Switches on the cPCI-8217*

Switch	Description
S1 (Tact)	LCD On/Off toggle switch
S2 (DIP)	LCD bit# selection
S3 (DIP)	Select LCD type & size

### 2.1.1 JP1&JP2: LCD positioning selection

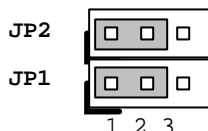

JP1	JP2	LCD Display
1-2	1-2	Normal *
2-3	2-3	Rotate 180°
1-2	2-3	R/L Reverse
2-3	1-2	U/D Reverse

\* Default setting: Normal

### 2.1.2 JP3: LCD VDD selection

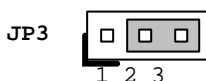

JP1	LCD VDD
1-2	+3.3V
2-3	+5V *

\* Default setting: +5V

### 2.1.3 S1: LCD On/Off Toggle switch

User can switch LCD on or off by this switch. This switch can control both LCD signals and backlight enable signal. However, user has to connect the backlight inverter's power cables on CN1 or CN5 to get the function of backlight enable or disable. If user use the cPCI-8217 with BIOS which supports VGA only, this switch will be disable.

## 2.1.4 S2: LCD bit# selection

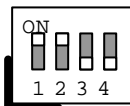

S2

Function	Setting			
	S2-1	S2-2	S2-3	S2-4
DSTN 16-bit *	On	---	---	---
DSTN 24-bit	Off	---	---	---
TFT 9-bit	---	On	On	On
TFT 12-bit	---	On	On	Off
TFT 18-bit	---	On	Off	On
TFT 24-bit *	---	On	Off	Off

\* Default setting: For DSTN: 16-bit; For TFT: 24-bit

## 2.1.5 S3: LCD type and size selection

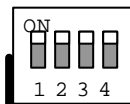

S3

LCD Size Selection	S3-1	S3-2
640 x 480 *	On	On
800 x 600	On	Off
1024 x 768	Off	On
1280 x 1024	Off	Off

\* Default setting: 640 x 480

FPCLK	S3-3
Normal *	On
Inverted	Off

\* Default setting: Normal

LCD Type Selection	S3-4
TFT *	On
DSTN	Off

\* Default setting: TFT

---

## 2.2 Connectors on the cPCI-8217

The connectors on the cPCI-8217 allows you to connect devices such as VGA monitor, LCD panel and back-light inverter. The following table lists the connectors on cPCI-8217 and their respective functions.

2.2.1	VGA Connector -- CN8.....	14
2.2.2	LCD Back-light Inverter Connector – CN1 and CN5.....	14
2.2.3	LCD Interface Connector – CN3.....	15
2.2.4	CompactPCI Connectors .....	17

### 2.2.1 VGA Connector – CN8

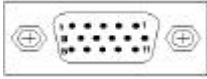

Signal Name	Pin	Pin	Signal Name
Red	1	2	Green
Blue	3	4	N.C.
GND	5	6	GND
GND	7	8	GND
+5V_CRT	9	10	GND
N.C.	11	12	CRTSDA
HSYNC	13	14	VSYNC
CRTSCL	15		

---

**Note:** CRTSDA: I<sup>2</sup>C Data, CRTSCL: I<sup>2</sup>C Clock.

---

### 2.2.2 LCD Back-light Inverter Connector – CN1 and CN5

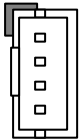

Pin #	Signal Name	Description
1	BRTADJ	Brightness Adjust
2	GND	Ground
3	ENBKL	Back Light Enable
4	+12VFP	+12V Power

## 2.2.3 LCD Interface Connector – CN3

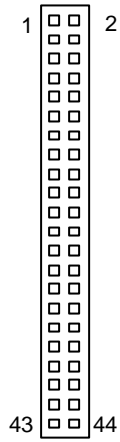

Signal Name	Pin #	Pin #	Signal Name
+12VFP	1	2	+12VFP
GND	3	4	GND
FPVDD	5	6	FPVDD
ENFPVEE	7	8	GND
FPD0	9	10	FPD1
FPD2	11	12	FPD3
FPD4	13	14	FPD5
FPD6	15	16	FPD7
FPD8	17	18	FPD9
FPD10	19	20	FPD11
FPD12	21	22	FPD13
FPD14	23	24	FPD15
FPD16	25	26	FPD17
FPD18	27	28	FPD19
FPD20	29	30	FPD21
FPD22	31	32	FPD23
GND	33	34	GND
SHFCLK	35	36	FLM
M/DE	37	38	LP
R/L	39	40	ENBKL
U/D	41	42	FPVEE
ENFPVDD	43	44	FPVDD

### Note :

1. FPVDD: LCD Power ( +5V or +3.3V ); ENFPVDD: FPVDD Enable; FPVEE: LCD Power ( +3.3V ); ENPFVEE: Voltage Bias Enable; FLM: DSTN LCD- Frame Pulse / TFT LCD- Vertical Sync Signal; LP: DSTN LCD – Line Pulse / TFT LCD - Horizontal Sync Signal; SHFCLK: Flat Panel Shift Pixel Clock; M/DE: Mode Select; R/L: Right-Left Reverse; U/D: Up-Side-Down; ENBKL: Back Light Enable.
2. The +12VFP (+12V power sources), which are designed to provide power to back light inverter, is protected by 1.1A auto-recovery fuse.

- 
3. LCD VDD is the power source for LCD logic circuit. The power of 3.3V or 5V voltage is selectable by JP3 on main board. The power ON/OFF is controlled by ENFPVDD signal. The power is with over-current protection by auto-recovery fuse.
  4. FPVVEE (LCD VDD) power source, which is controlled by the ENFPVVEE signal, comes from +3.3V. The power is with over-current protection by auto-recovery fuse. This power is for providing the LCD bias voltage.
-

## 2.2.4 CompactPCI Connectors

cPCI-8217 series use standard 2.0mm Hard Metric Connector for CompactPCI bus connection. The cPCI-8217 series are designed for 32-bit/33MHz PCI bus signaling. The model cPCI-8217 comes with only CompactPCI J1 connector, without CompactPCI J2 connector, that provides the safety to insert it into 64-bit or PXI backplanes. The model cPCI-8217R comes with both CompactPCI J1 and J2 connectors, which is designed for routing LCD signals to the rear I/O transition module. Please don't insert cPCI-8217R into 64-bit, PXI or other backplanes with proprietary bus on CompactPCI P2/J2.

---

**Warning:** It might cause system or boards damage if insert cPCI-8217R (which with cPCI J2 connector) into 64-bit, PXI or other backplanes with proprietary bus on CompactPCI P2/J2.

---

- **J1 Pin Assignments of cPCI-8217 (support 32-bit peripheral slot)**

Pin	Z	A	B	C	D	E	F
25	GND	+5V	NC	NC	+3.3V	+5V	GND
24	GND	AD[1]	+5V	NC	AD[0]	NC	GND
23	GND	+3.3V	AD[4]	AD[3]	+5V	AD[2]	GND
22	GND	AD[7]	GND	+3.3V	AD[6]	AD[5]	GND
21	GND	+3.3V	AD[9]	AD[8]	NC	C/BE[0]#	GND
20	GND	AD[12]	GND	NC	AD[11]	AD[10]	GND
19	GND	+3.3V	AD[15]	AD[14]	GND	AD[13]	GND
18	GND	NC	GND	+3.3V	PAR	C/BE[1]#	GND
17	GND	+3.3V	NC	NC	GND	NC	GND
16	GND	DEVSEL#	GND	NC	STOP#	NC	GND
15	GND	+3.3V	FRAME#	IRDY#	NC	TRDY#	GND
12-14	KEY						
11	GND	AD[18]	AD[17]	AD[16]	GND	C/BE[2]#	GND
10	GND	AD[21]	GND	+3.3V	AD[20]	AD[19]	GND
9	GND	C/BE[3]#	IDSEL	AD[23]	GND	AD[22]	GND
8	GND	AD[26]	GND	NC	AD[25]	AD[24]	GND
7	GND	AD[30]	AD[29]	AD[28]	GND	AD[27]	GND
6	GND	REQ#	GND	+3.3V	CLK	AD[31]	GND
5	GND	NC	NC	RST#	GND	GNT#	GND
4	GND	NC	NC	NC	NC	NC	GND
3	GND	INTA#	NC	NC	+5V	NC	GND
2	GND	NC	+5V	NC	NC	NC	GND
1	GND	+5V	NC	NC	+12V	+5V	GND
Pin	Z	A	B	C	D	E	F

- **J2 Pin Assignments of cPCI-8217R (support 32-bit peripheral slot with rear I/O)**

Pin	Z	A	B	C	D	E	F
22	GND	GA4	GA3	GA2	GA1	GA0	GND
21	GND	NC	GND	NC	NC	NC	GND
20	GND	NC	GND	NC	GND	NC	GND
19	GND	GND	GND	NC	NC	NC	GND
18	GND	NC	NC	NC	GND	NC	GND
17	GND	NC	GND	NC	NC	NC	GND
16	GND	NC	NC	NC	GND	NC	GND
15	GND	NC	GND	NC	NC	NC	GND
14	GND	FPVDD	SHFCLK	ENFPVDD	GND	NC	GND
13	GND	FPVDD	GND	NC	NC	NC	GND
12	GND	+12VFP	FPVEE	FLM	GND	M/DE	GND
11	GND	LP	GND	NC	FPD17	ENFPVEE	GND
10	GND	FPD11	FPD13	FPD15	GND	ENBKL	GND
9	GND	FPD9	GND	NC	FPD10	FPD23	GND
8	GND	FPD7	FPD14	FPD20	GND	FPD21	GND
7	GND	FPD4	GND	NC	FPD8	FPD19	GND
6	GND	FPD2	FPD16	FPD22	GND	FPD5	GND
5	GND	FPD0	FPD12	NC	FPD6	FPD3	GND
4	GND	NC	NC	FPD18	GND	FPD1	GND
3	GND	NC	NC	GND	NC	NC	GND
2	GND	NC	NC	NC	NC	NC	GND
1	GND	NC	GND	NC	NC	NC	GND
Pin	Z	A	B	C	D	E	F

---

## 2.3 More features on the cPCI-8217 panel

There are several special features for cPCI-8217 such as LCD on/off switch and brightness adjustment. Those features can be accessed by user on the cPCI-8217 panel. User can also get the operating status from the LED indicators on the front of cPCI-8217 faceplate.

### 2.3.1 LCD brightness adjustment knob

User can adjust LCD brightness by rotating this knob. However, user has to connect the backlight inverter's power cables on CN1 or CN5 to get the function of LCD brightness adjustment. Also, the backlight inverter in LCD is required to support brightness adjustment function. If user use the cPCI-8217 with BIOS which supports VGA only, this switch will be disable.

### 2.3.2 LCD On indicator (Green LED)

This LED will be light if the LCD signals and the backlight enable signal are on. If user use the cPCI-8217 with BIOS which supports VGA only, this LED will be disable.

---

**Note:** This LED just indicates the LCD status only. No relationship with VGA display status.

---

### 2.3.3 LCD power saving indicator (Amber LED)

This LED will be light if the LCD signals and the backlight enable signal are switched off. It will occur if user pushed the S1 button to toggle the LCD display to power saving mode or if the computer is in power saving mode controlled by APM (Advanced Power Management). If user use the cPCI-8217 with BIOS which supports VGA only, it means that LCD signals are permanently off, this LED will be always on.

---

**Note:** This LED just indicates the LCD status only. No relationship with VGA display status.

---

# Driver Installation

To install the drivers for the cPCI-8217, please refer the detail installation information from this Chapter. We provide the basic information in this manual, however, for more detail installation information, such as non-Windows OS installation, please refer the extensive explanation inside the ADLINK CD.

---

## 3.1 VGA Drivers Installation

This chapter describes VGA driver installation for the onboard VGA/LCD controller **SM721**. The relative drivers are in the following ADLINK CD directory: **X:\CHIPDRV\VGA\SM721**, where X: is the location of the CD-ROM drive. The VGA drivers for Windows 98/95, Windows NT and Windows 2000 are included.

### 3.1.1 Driver Installation on Windows 2000

The Windows 2000 may install the standard VGA driver. We recommend you to manually installed the most updated driver, which shipped with ADLINK CD to guarantee the compatibility. After installing the Windows 2000, please update the new drivers by the following procedures.

1. Boot Windows2000, Click **Start**. Select **Settings** then double-click the **Control Panel**.
2. Double-click on the **System** icon, click **Hardware** tab, click **Device Manager** button.

3. Double-click either on the *Display Adapters* or *Other Devices* entry, Double-click the *Video Controller* or Silicon Motion Lynx3DM entry.
4. Click on the **Driver** tab, then click **Update Driver...** button.
5. An Upgrade Device Driver Wizard windows, click **NEXT>**.
6. Select *Display a list of ...* and click **NEXT**.
7. The next window may show a list of hardware type, then select **Display Adapters**, then click **OK**.
8. This window may show a list of VGA model numbers.
9. Insert ADLINK CD and click **Have Disk**.
10. **Browse** the SM721 driver in the following path: **X:\CHIPDRV\VGA\SM721\WIN2K**, highlight **smisetup.inf**, click **OPEN**, then click **NEXT>**.
11. Highlight the model: **Silicon Motion Lynx3DM**, then click **NEXT>**.
12. Click **NEXT>** button, The Windows 2000 may report Digital Signature Not Found, then click **Yes** to continue.
13. Click **Finish** button, then click **CLOSE** button.

### 3.1.2 Driver Installation on Windows 98

The Windows 98 may install the standard VGA driver. We recommend you to manually installed the most updated driver, which shipped with ADLINK CD to guarantee the compatibility. After installing Windows 98, please update the new drivers by the following procedures.

1. Boot Windows 98, Click **Start**. Select **Settings** then double-click the **Control Panel**.
2. Double-click **System** icon, click on the **Device Manager** tab.
3. Double-click **Display Adapters** entry, select the **Standard PCI Graphics Adapter (VGA)** entry. Click the **Properties** button.
4. Click on the **Driver** button, then click **Update Driver...** button.
5. An Upgrade Device Driver Wizard windows, click **NEXT>**.
6. Select **Display a list of ...** and click **NEXT>**. The next window allows the user to specify a specific path. Insert the ADLINK CD and click **Have Disk**.
7. **Browse** the SM721 driver in the following path: **X:\CHIPDRV\VGA\SM721\WIN9X**, highlight **smi.inf**, click **OPEN**. Click **OK**.
8. Click **NEXT>** button, then the Wizard summary window appears.
9. Click **Finish** button, then restart the computer to active the new driver.

### 3.1.3 Driver Installation on Windows NT

The Windows NT may install the standard VGA driver while. We recommend you to manually installed the most updated driver, which shipped with ADLINK CD to guarantee the compatibility. After installing Windows NT, please update the new drivers by the following procedures.

1. From the **Control Panel**, double-click the **Display** icon.
2. Click the **Settings** tab, click **Display Type...**, click **Change...** button.
3. Insert ADLINK CD and click **Have Disk**.
4. **Browse** the SM721 driver in the following path: **X:\CHIPDRV\VGA\SM721WT40**, highlight **smisetup.inf**, click **OPEN**. Click **OK**.
5. A windows shows the Display is Silicon Motion Lynx Family, click **OK**, then click **Yes** to continue.
6. An Installing Driver window shows successful installing, click **OK** to continue.
7. Click **Close** button.
8. Click **Close** button, then restart the computer to active the new driver.

## Product Warranty/Service

ADLINK warrants that equipment furnished will be free from defects in material and workmanship for a period of one year from the date of shipment. During the warranty period, we shall, at our option, either repair or replace any product that proves to be defective under normal operation.

This warranty shall not apply to equipment that has been previously repaired or altered outside our plant in any way as to, in the judgment of the manufacturer, affect its reliability. Nor will it apply if the equipment has been used in a manner exceeding its specifications or if the serial number has been removed.

ADLINK does not assume any liability for consequential damages as a result from our product uses, and in any event our liability shall not exceed the original selling price of the equipment. The remedies provided herein are the customer's sole and exclusive remedies. In no event shall ADLINK be liable for direct, indirect, special or consequential damages whether based on contract of any other legal theory.

The equipment must be returned postage-prepaid. Package it securely and insure it. You will be charged for parts and labor if the warranty period is expired or the product is proves to be misuse, abuse or unauthorized repair or modification.