TIP670

Digital I/O

Version 1.0 Revision B

User Manual

Issue 1.3

December 2002

D75670800

TIP670-10

8 isolated digital inputs, 8 isolated digital outputs

TIP670-20

4 isolated digital inputs, 4 isolated digital outputs

This document contains information, which is proprietary to TEWS TECHNOLOGIES GmbH. Any reproduction without written permission is forbidden.

TEWS TECHNOLOGIES GmbH has made any effort to ensure that this manual is accurate and complete. However TEWS TECHNOLOGIES GmbH reserves the right to change the product described in this document at any time without notice.

TEWS TECHNOLOGIES GmbH is not liable for any damage arising out of the application or use of the device described herein.

Style Conventions

Hexadecimal characters are specified with prefix 0x, i.e. 0x029E (that means hexadecimal value 029E).

For signals on hardware products, an ‚Active Low’ is represented by the signal name with # following, i.e. IP_RESET#.

Access terms are described as:

- W Write Only
- R Read Only
- R/W Read/Write
- R/C Read/Clear
- R/S Read/Set

©1994-2002 by TEWS TECHNOLOGIES GmbH

Issue	Description	Date
1.0	First Issue	June 1994
1.1	Technical Specification	April 1996
1.2	General Revision	November 2002
1.3	Correction "Product Description"	December 2002

Table of Contents

1	PRODUCT DESCRIPTION	5
2	TECHNICAL SPECIFICATION	6
3	ID PROM CONTENTS	7
4	IP ADDRESSING	8
	4.1 Indirect Addressable Registers	8
5	FUNCTIONAL DESCRIPTION	11
	5.1 Digital Inputs	11
	5.1.1 Optical Isolation	11
	5.1.2 Digital Filtering	11
	5.1.3 Input and Interrupt Logic.....	11
	5.2 Digital Outputs	11
	5.2.1 Optical Isolation	11
	5.2.2 Output Polarity	11
	5.2.3 Overload Protection	11
	5.2.4 Output Watchdog.....	12
6	PROGRAMMING	13
	6.1 Required Software Initialization	13
	6.2 Initialization of the Watchdog Function	14
7	INSTALLATION	16
	7.1 Input Wiring	16
	7.2 Output Wiring	17
8	PIN ASSIGNMENT – I/O CONNECTOR	18
	8.1 Input Connections	18
	8.2 Output Connections	19

Table of Figures

FIGURE 1-1 : BLOCK DIAGRAM.....	5
FIGURE 2-1 : TECHNICAL SPECIFICATION.....	6
FIGURE 3-1 : ID PROM CONTENTS	7
FIGURE 4-1 : REGISTER SET	8
FIGURE 4-2 : Z8536 CIO INDIRECT ADDRESSABLE REGISTERS	9
FIGURE 4-3 : CIO STATE MACHINE	10
FIGURE 7-1 : INPUT WIRING OPTIONS	16
FIGURE 7-2 : OUTPUT WIRING AS HIGH SIDE SWITCH.....	17
FIGURE 7-3 : OUTPUT WIRING AS LOW SIDE SWITCH.....	17
FIGURE 8-1 : INPUT I/O CONNECTION.....	18
FIGURE 8-2 : OUTPUT I/O CONNECTION.....	19

1 Product Description

The TIP670 is an IndustryPack® compatible module with 8 (4) digital inputs galvanically isolated by optocoupler. The individual inputs are potential free in relation to each other. A high performance input circuit ensures a defined switching point and polarization protection against confusing the pole.

All inputs have an electronic debounce circuit with fixed debounce time. All inputs can generate an interrupt. The signal edge handling is programmable. For systems with particularly fast reaction, each input can be assigned its own interrupt vector.

The TIP670 has 8 (4) digital outputs with galvanic isolation via optocouplers. The outputs are isolated against each other in groups of two. All outputs resist short-circuits and are protected against thermal overload.

The output drivers are capable of driving 0.5A continuous per channel. Each output can be configured individually as high or low side switch.

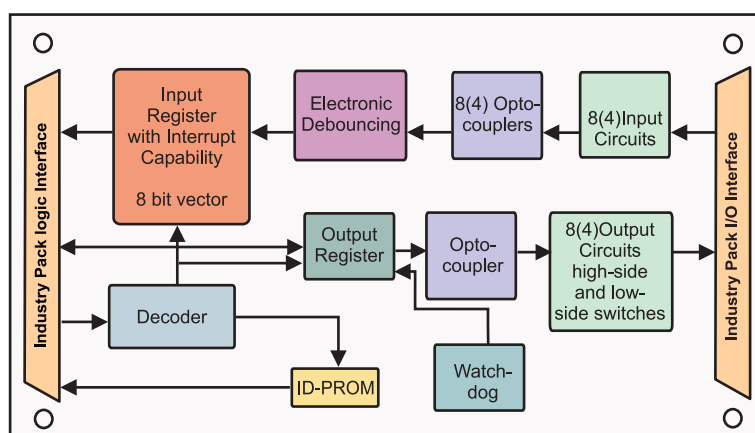

Figure 1-1 : Block Diagram

2 Technical Specification

Logic Interface	Single Size IndustryPack® Logic Interface compliant to ANSI/VITA 4-1995	
Interface Connector	50-conductor flat cable	
Number of Inputs	TIP670-10: 8 TIP670-20: 4	
Input Isolation	All channels are completely independent from each other	
Input Voltage	24V DC	
Input Current	4.2mA typical @+24V input voltage	
Input Switching Level	12V typical (minimum 9V, maximum 13V)	
Wait States	ID PROM: 0 wait states I/O (Z8536 CIO): minimum 3 wait states	
Number of Digital Outputs	TIP670-10: 8 TIP670-20: 4	
Output Isolation	All channels, each two channels shares the same power supply and ground	
External Supply Voltage for Outputs	24V DC typical 6V DC minimum 48V DC maximum	
Output Current	0.5A (0.4A for voltages over 32V)	
Short Circuit Current	0.8A typical (2A maximum)	
Output Voltage Drop	1.1V typical @+0.5A	
Output Protection	Overload, short circuit, GND and Vs open wire protection, thermal shutdown	
Power Requirements	TIP670-10: 280mA typical @+5V DC (all inputs and outputs active) TIP670-20: 250mA typical @+5V DC (all inputs and outputs active)	
Temperature Range	Operating	0 °C to +70 °C
	Storage	-45°C to +125°C
MTBF	920276 h	
Humidity	5 – 95 % non-condensing	
Transition Module	Optional (TIP001-TM-10)	

Figure 2-1 : Technical Specification

3 ID Prom Contents

Address	Function	Contents
0x01	ASCII 'I'	0x49
0x03	ASCII 'P'	0x50
0x05	ASCII 'A'	0x41
0x07	ASCII 'C'	0x43
0x09	Manufacturer ID	0xB3
0x0B	Model Number	0x02 (for TIP670-10) 0x03 (for TIP670-20)
0x0D	Revision	0x10
0x0F	Reserved	0x00
0x11	Driver-ID low byte	0x00
0x13	Driver-ID high byte	0x00
0x15	Number of bytes used	0x0C
0x17	CRC	0x93 (for TIP670-10) 0xF2 (for TIP670-20)

Figure 3-1 : ID PROM Contents

4 IP Addressing

The TIP670 is accessed in the I/O space through the following set of four direct accessible registers implemented in the Z8536 controller:

Address	Symbol	Description	Size (Bit)
0x01	PORTC	Port C Data Bits D00-D07	8
0x03	PORTB	Port B Data Bits D00-D07	8
0x05	PORTA	Port A Data Bits D00-D07	8
0x07	CIOCSR	CIO Command and Status Register	8

Figure 4-1 : Register Set

4.1 Indirect Addressable Registers

In addition to the above mentioned direct access registers the Z8536 CIO has 48 indirect addressable registers. These indirect addressable registers are used for the mode specification and for the control of ports and counter/timers.

Not all of the indirect addressable registers are required for the operation of the TIP670. For a more detailed description of the function of these registers see the Z8536 data sheet which is part of the Engineering Documentation TIP670-ED.

Address	Symbol	Description	Size (Bit)
0x00	MICR	Master Interrupt Control	8
0x01	MCCR	Master Configuration Control	8
0x02	PAIV	Port A Interrupt Vector	8
0x03	PBIV	Port B Interrupt Vector	8
0x04	CTIV	Counter / Timer Interrupt Vector	8
0x05	PCDP	Port C Data Path Polarity	8
0x06	PCDD	Port C Data Direction	8
0x07	PCSC	Port C Special I/O Control	8
0x08	PACS	Port A Control / Status	8
0x09	PBCS	Port B Control / Status	8
0x0A	C1CSR	Counter / Timer 1 Command / Status	8
0x0B	C2CSR	Counter / Timer 2 Command / Status	8
0x0C	C3CSR	Counter / Timer 3 Command / Status	8
0x0D	PADR	Port A Data Register	8
0x0E	PBDR	Port B Data Register	8
0x0F	PCDR	Port C Data Register	8
0x10	CT1CM	Counter / Timer 1 Current Count MSB	8
0x11	CT1CL	Counter / Timer 1 Current Count LSB	8
0x12	CT2CM	Counter / Timer 2 Current Count MSB	8

0x13	CT2CL	Counter / Timer 2 Current Count LSB	8
0x14	CT3CM	Counter / Timer 3 Current Count MSB	8
0x15	CT3CL	Counter / Timer 3 Current Count LSB	8
0x16	CT1PM	Counter / Timer 1 Preload MSB	8
0x17	CT1PL	Counter / Timer 1 Preload LSB	8
0x18	CT2PM	Counter / Timer 2 Preload MSB	8
0x19	CT2PL	Counter / Timer 2 Preload LSB	8
0x1A	CT3PM	Counter / Timer 3 Preload MSB	8
0x1B	CT3PL	Counter / Timer 3 Preload LSB	8
0x1C	CT1MO	Counter / Timer 1 Mode Specification	8
0x1D	CT2MO	Counter / Timer 2 Mode Specification	8
0x1E	CT3MO	Counter / Timer 3 Mode Specification	8
0x1F	CTCV	Counter / Timer Current Vector	8
0x20	PAMO	Port A Mode Specification	8
0x21	PAHS	Port A Handshake Specification	8
0x22	PADP	Port A Data Path Polarity	8
0x23	PADD	Port A Data Direction	8
0x24	PASC	Port A Special I/O Control	8
0x25	PAPP	Port A Pattern Polarity	8
0x26	PAPT	Port A Pattern Transition	8
0x27	PAPM	Port A Pattern Mask	8
0x28	PBMO	Port B Mode Specification	8
0x29	PBHS	Port B Handshake Specification	8
0x2A	PBDP	Port B Data Path Polarity	8
0x2B	PBDD	Port B Data Direction	8
0x2C	PBSC	Port B Special I/O Control	8
0x2D	PBPP	Port B Pattern Polarity	8
0x2E	PBPT	Port B Pattern Transition	8
0x2F	PBPM	Port B Pattern Mask	8

Figure 4-2 : Z8536 CIO Indirect Addressable Registers

The access to the indirect addressable register is controlled by a state machine and a hidden pointer register. The state machine takes 3 different states: RESET state, state " 0 " or state " 1 " .

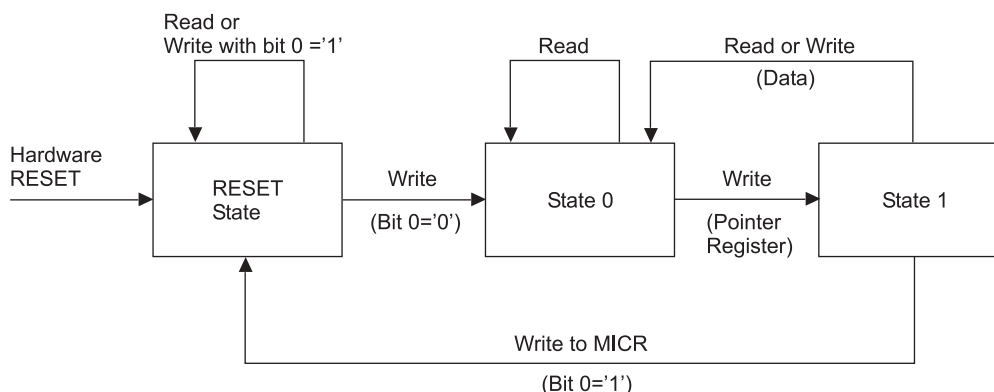

Figure 4-3 : CIO State Machine

A hardware reset will put the state machine into RESET state. In RESET state it is only possible to read or write the RESET bit (bit 0) in the Master Interrupt Control Register (MICR). A write access with the RESET bit (bit 0) = 0 will put the state machine into state " 0 " .

Writing in state " 0 " loads the internal pointer register with the internal register address to select the chosen register. This will put also the state machine into state " 1 " .

A read or write access in state " 1 " will transfer data from or to the internal register which was selected by the pointer register. Any access to the internal registers puts the state machine back into state " 0 " .

Any read in state " 0 " returns the contents of the last register pointed to. Therefore, a register can be read continuously without again writing to the pointer.

Outside the RESET state any read will put the state machine into state '0'. So a dummy read can be used to bring the state machine in this known state.

If the state machine is in state '1', some of the internal operation of the CIO is disabled. So the state machine should never be left in state '1' longer as necessary.

Direct accesses to the data register PORTA, PORTB, and PORTC have no consequence for the status of the state machine.

5 Functional Description

5.1 Digital Inputs

5.1.1 Optical Isolation

The TIP670 has 8 (TIP670-10) or 4 (TIP670-20) digital inputs. The standard signal level for these inputs is 24V DC. The switching level of the inputs is between 8 and 13 volts. All input channels are isolated by AC optocoupler and are also isolated against each other. The use of AC optocoupler makes the operation of the inputs independent from signal polarity.

5.1.2 Digital Filtering

A digital filter circuit is provided for input switch debouncing. The debounce time is adjusted by a capacitor to approximately 12ms.

5.1.3 Input and Interrupt Logic

The input and interrupt logic is implemented in the Z8536 port controller circuit. The digitally filtered input signals are connected with port B of the Z8536.

Interrupt generation can be individually programmed for each channel and input transition. For more detailed information see the Z8536 data manual which is part of the TIP670-ED Engineering Documentation.

A software initialization of the Z8536 is required before the input states can be read at port B.

5.2 Digital Outputs

5.2.1 Optical Isolation

The TIP670 has 8 (TIP670-10) or 4 (TIP670-20) digital outputs. The standard signal level for these outputs is 24V DC. All output channels are isolated by optocoupler and are also isolated against each other in groups of two outputs.

5.2.2 Output Polarity

Each output can be individually configured as a high or a low side switch depending on the external wiring of the output signal lines.

5.2.3 Overload Protection

The output drivers are implemented by smart drivers TDExxx. The maximum continuous output current is 0.5A. The output circuits are protected against overload, short circuit and thermal overload. In case of such a failure the corresponding output will be disabled until the error condition is removed. Then the output returns automatically to normal operation.

5.2.4 Output Watchdog

Counter/Timer 3 and Port C of the Z8536 can be programmed to implement a watchdog for the outputs. Any software access to the Z8536 will retrigger Timer 3 in the Z8536. If the programmed time expires without a software access all outputs go into the 'off' state (the maximum programmable time is approx. 30ms). However they will return to their original state, when the TIP670 is accessed again by the software.

The watchdog is disabled after power-up or reset.

6 Programming

After power-up or system reset the CIO Z8536 is in its initial state and the I/O ports A, B, C are disabled and configured to output direction. For normal operation of the TIP670 a minimum software initialization is required.

6.1 Required Software Initialization

The input lines of the TIP670 are connected to port B of the CIO Z8536. This port has to be configured as input and because of the inverting function of the optocouplers the input polarity has to be set to inverting.

To perform this required software initialization see the following procedure:

- Write 0x00 to CIOCSR
Write 0x01 to CIOCSR
Write 0x00 to CIOCSR
This sequence puts the CIO Z8536 into a known (reset) state
- Write 0x2B to CIOCSR
This selects the Port B Data Direction Register (PBDD) for the next operation
- Write 0xFF to CIOCSR
Writing 0xFF into PBDD will configure all bits of port B as input
- Write 0x2A to CIOCSR
This selects the Port B Data Path Polarity Register (PBDP) for the next operation
- Write 0xFF to CIOCSR
Writing 0xFF into PBDP will configure all bits of port B to be inverted
- Write 0x01 to CIOCSR
This selects the Master Configuration Control Register (MCCR) for the next operation
- Write 0x84 to CIOCSR
Writing 0x84 into MCCR will enable port A and B

After this sequence the directly accessible port registers Port A and Port B can be used for reading the actual status of the TIP670 input and setting the TIP670 outputs.

6.2 Initialization of the Watchdog Function

On the TIP670 port C and counter timer 3 of the Z8536 are wired in way, that a watchdog function can be programmed into the TIP670. This watchdog is retriggered with every access to the TIP670. If there is no access within a previously programmed time frame, the watchdog will automatically disable the output lines.

If the TIP670 is accessed after the watchdog timer has expired, the output lines will return to its original state.

For initialization of the watchdog function proceed as follow:

- Write 0x1E to CIOCSR
This selects the Counter/Timer 3 Mode Specification Register (CT3MO) for the next operation
- Write 0x55 to CIOCSR
Writing 0x55 into CT3MO will configure counter/timer 3 to single cycle, retrigger enable, external output, one shot
- Write 0x1A to CIOCSR
This selects the Counter/Timer3 Preload MSB Register (CT3PM) for the next operation
- Write 0xF0 to CIOCSR
Writing 0xF0 into CT3PM will load the first half of the watchdog time out time of '0xF000' which is just an example for approx. 30ms
- Write 0x1B to CIOCSR
This selects the Counter/Timer3 Preload LSB Register (CT3PL) for the next operation
- Write 0x00 to CIOCSR
Writing 0x00 into CT3PL will load the second half of the watchdog time out time of '0xF000' which is just an example for approx. 30ms
- Write 0x06 to CIOCSR
This selects the Port C Data Direction Register (PCDD) for the next operation
- Write 0x04 to CIOCSR
Writing 0x04 into PCDD configures bit 2 as an input for retrigger
- Write 0x01 to CIOCSR
This selects the Master Configuration Control Register (MCCR) for the next operation
- Write 0x84 to CIOCSR
Writing 0x84 into MCCR will enable port A and B
- Write 0x0F to CIOCSR
This selects the Port C Data Register (PCDR) for the next operation
- Write 0x70 to CIOCSR
Writing 0x70 into PCDR configures bit 3 as an writable output

- Write 0x0C to CIOCSR
This selects the Counter/Timer 3 Command and Status Register (C3CSR) for the next operation
- Write 0x06 to CIOCSR
Writing 0x06 into C3CSR triggers and runs counter timer 3
- Write 0x00 to PORTC
Writing 0x00 to PORTC will enable the watchdog function

7 Installation

7.1 Input Wiring

Each input is optically isolated from the logic circuit. Each input is independent of the other inputs and can be wired different. Each input has two connections at the IP I/O connector, Input x + and Input x -. However the TIP670 has AC optocoupler at the input side. Therefore the polarity of the input signal may be either way.

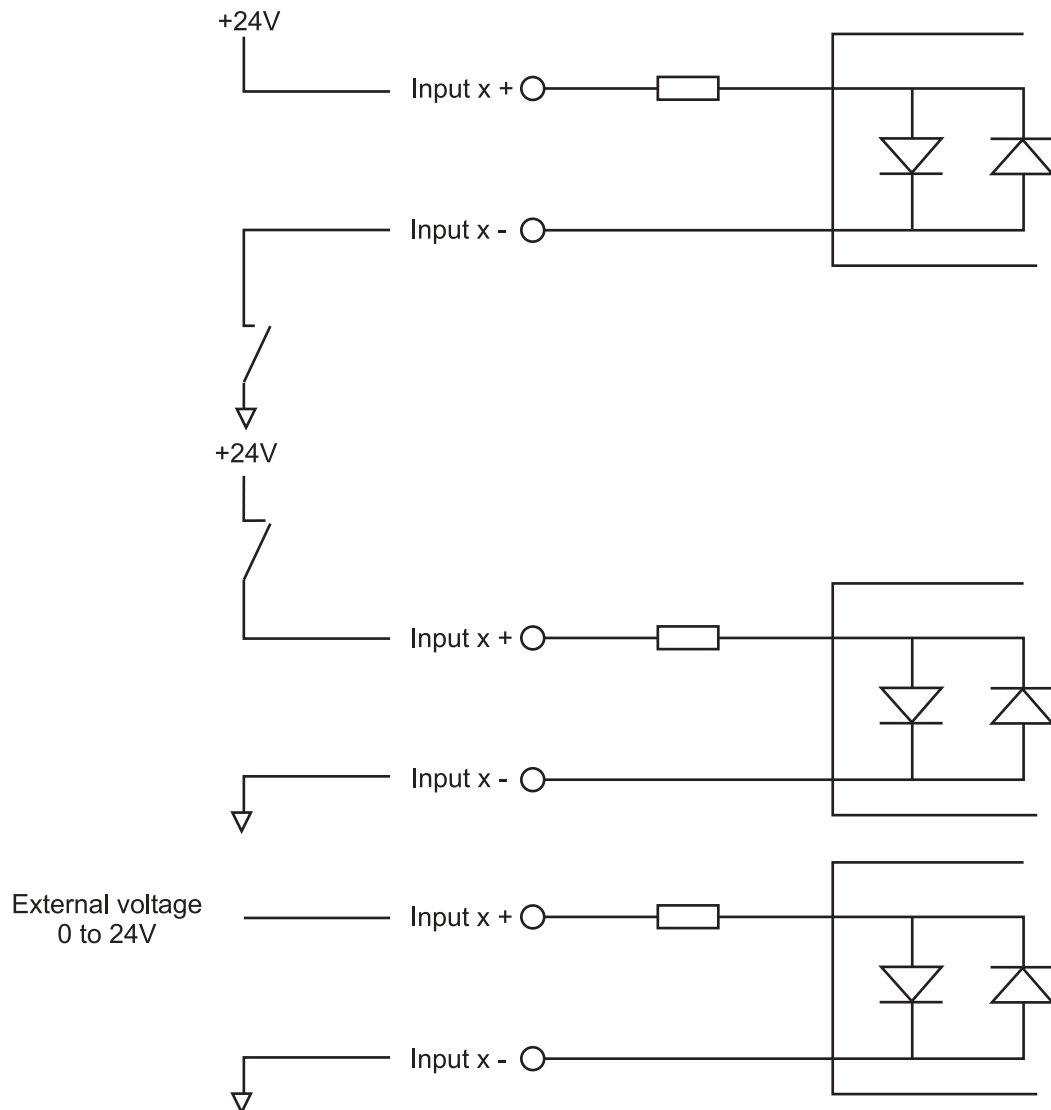

Figure 7-1 : Input Wiring Options

7.2 Output Wiring

The outputs are optically isolated from the logic circuit in groups of two. Output channels 1 and 2, 3 and 4, 5 and 6, 7 and 8 share the same output potential but are completely isolated against the other output pairs.

Each output can be individually configured as a high side or a low side switch by corresponding wiring.

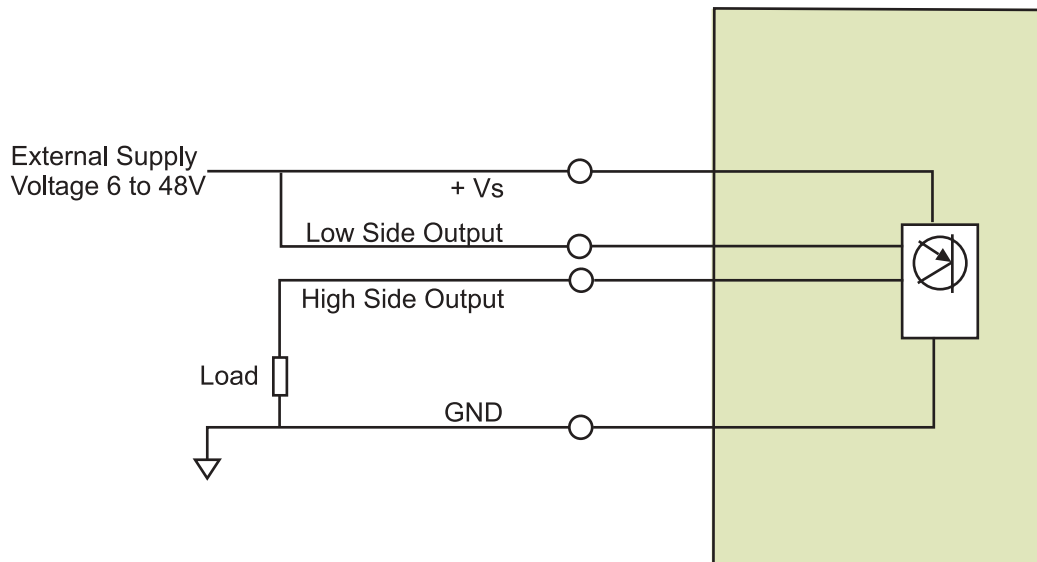

Figure 7-2 : Output Wiring as High Side Switch

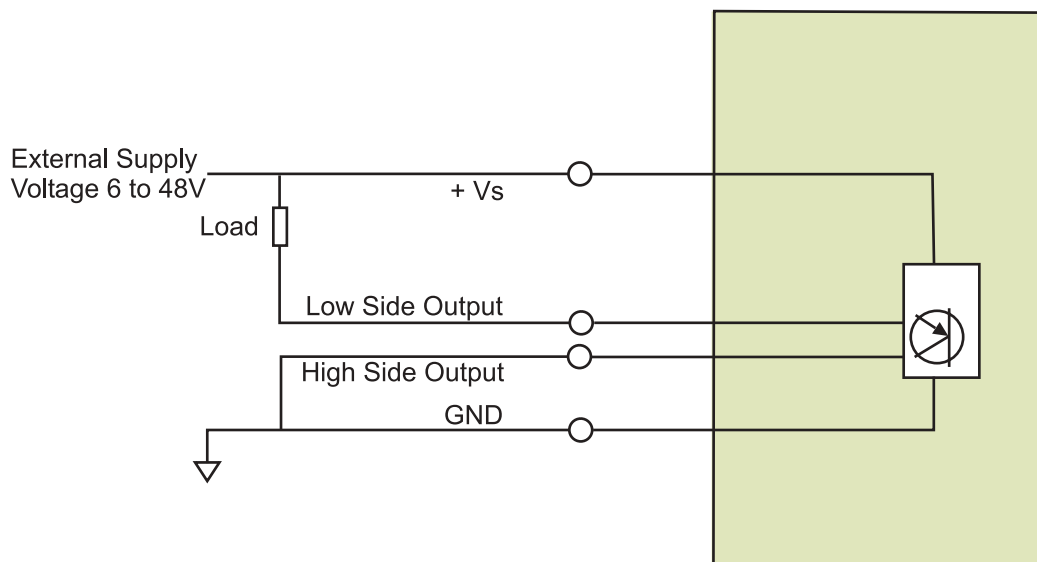

Figure 7-3 : Output Wiring as Low Side Switch

8 Pin Assignment – I/O Connector

8.1 Input Connections

Pin	Signal	Comment
01	Input 1+	
02	Input 1-	
03	Input 2+	
04	Input 2-	
05	Input 3+	
06	Input 3-	
07	Input 4+	
08	Input 4-	
09	Input 5+	TIP670-10 only
10	Input 5-	TIP670-10 only
11	Input 6+	TIP670-10 only
12	Input 6-	TIP670-10 only
13	Input 7+	TIP670-10 only
14	Input 7-	TIP670-10 only
15	Input 8+	TIP670-10 only
16	Input 8-	TIP670-10 only

Figure 8-1 : Input I/O connection

8.2 Output Connections

Pin	Signal	Comment
26	GND 1-2	External GND for Output 1-2
27	GND 3-4	External GND for Output 3-4
28	GND 5-6	External GND for Output 5-6 (TIP670-10 only)
29	GND 7-8	External GND for Output 7-8 (TIP670-10 only)
30	Low Side Output 1	
31	High Side Output 1	
32	Low Side Output 2	
33	High Side Output 2	
34	Low Side Output 3	
35	High Side Output 3	
36	Low Side Output 4	
37	High Side Output 4	
38	Low Side Output 5	TIP670-10 only
39	High Side Output 5	TIP670-10 only
40	Low Side Output 6	TIP670-10 only
41	High Side Output 6	TIP670-10 only
42	Low Side Output 7	TIP670-10 only
43	High Side Output 7	TIP670-10 only
44	Low Side Output 8	TIP670-10 only
45	High Side Output 8	TIP670-10 only
46	+Vs 1-2	External Supply Voltage for Output 1-2
47	+Vs 3-4	External Supply Voltage for Output 3-4
48	+Vs 5-6	External Supply Voltage for Output 5-6 (TIP670-10 only)
49	+Vs 7-8	External Supply Voltage for Output 7-8 (TIP670-10 only)
50	NC	

Figure 8-2 : Output I/O connection