TPMC467

Channel RS232/RS422/RS485

Programmable Serial Interface

Version 1.0

User Manual

Issue 1.0.3

December 2009

TPMC467-10

4 Channel RS232/RS422/RS485 Programmable
Serial Interface, front panel I/O

TPMC467-11

4 Channel RS232/RS422/RS485 Programmable
Serial Interface, front panel I/O with non standard
RJ45 I/O pinout

This document contains information, which is proprietary to TEWS TECHNOLOGIES GmbH. Any reproduction without written permission is forbidden.

TEWS TECHNOLOGIES GmbH has made any effort to ensure that this manual is accurate and complete. However TEWS TECHNOLOGIES GmbH reserves the right to change the product described in this document at any time without notice.

TEWS TECHNOLOGIES GmbH is not liable for any damage arising out of the application or use of the device described herein.

Style Conventions

Hexadecimal characters are specified with prefix 0x, i.e. 0x029E (that means hexadecimal value 029E).

For signals on hardware products, an 'Active Low' is represented by the signal name with # following, i.e. IP_RESET#.

Access terms are described as:

W	Write Only
R	Read Only
R/W	Read/Write
R/C	Read/Clear
R/S	Read/Set

©2006-2009 by TEWS TECHNOLOGIES GmbH

All trademarks mentioned are property of their respective owners.

Issue	Description	Date
1.0	First Issue	August 2006
1.1	New address TEWS LLC	September 2006
1.2	Technical Specification update	January 2007
1.0.3	New notation for HW Engineering Documentation Releases	December 2009

Table of Contents

1	PRODUCT DESCRIPTION	6
2	TECHNICAL SPECIFICATION	7
3	LOCAL SPACE ADDRESSING	8
	3.1 XR17D154 Local Space Configuration.....	8
	3.2 Device Configuration Space	8
	3.2.1 UART Register Sets.....	9
	3.2.2 Device Configuration Registers	10
	3.2.3 UART Channel Configuration Registers	11
4	XR17D154 TARGET CHIP	13
	4.1 PCI Configuration Registers (PCR).....	13
	4.2 Configuration EEPROM.....	14
5	CONFIGURATION HINTS	16
	5.1 CPLD Description.....	16
	5.1.1 CPLD Address Map	16
	5.1.2 Channel Control Register.....	16
	5.2 CPLD Access.....	17
	5.2.1 Accessing XR17D154 MPIO-Pins.....	18
	5.2.2 CPLD-Bus Protocol.....	18
	5.2.2.1 Write	18
	5.2.2.2 Read	19
	5.3 Serial Interface Channel Setup	20
	5.3.1 Special Features	20
	5.3.1.1 Auto RS485 Operation	20
	5.3.1.2 RS485 Receiver Control.....	20
	5.3.1.3 Stew Rate Limiting.....	21
	5.3.1.4 Low-Power Shutdown.....	21
	5.3.2 Channel Setup	21
	5.4 RS485/RS422 Configuration Examples.....	22
	5.4.1 RS422 Multidrop	22
	5.4.2 RS422 Full Duplex Point to Point.....	22
	5.4.3 RS485 Full Duplex Point to Point.....	22
	5.4.4 RS485 Half Duplex Point to Point.....	23
	5.4.5 RS485 Full Duplex Multi-point	23
	5.4.6 RS485 Half Duplex Multi-point.....	24
	5.5 I/O Electrical Interface	24
	5.5.1 ±15kV ESD Protection	24
	5.5.2 RS232 Transceivers.....	24
	5.5.3 RS485/RS422 Transceivers	24
	5.5.4 Termination	25
	5.6 Block Diagram	25
6	PROGRAMMING HINTS	26
	6.1 UART Baud Rate Programming.....	26
7	PIN ASSIGNMENT – I/O CONNECTOR	28
	7.1 Front Panel I/O Connector (TPMC467-10).....	28
	7.2 Front Panel I/O Connector (TPMC467-11).....	28
	7.3 Serial Channel to Front Panel Port Mapping.....	29

List of Figures

FIGURE 1-1 : BLOCK DIAGRAM.....	6
FIGURE 5-1 : CPLD-BUS BLOCK DIAGRAM	17
FIGURE 5-2 : CPLD-BUS WRITE.....	18
FIGURE 5-3 : CPLD-BUS READ	19
FIGURE 5-4 : RS422 MULTIDROP CONFIGURATION	22
FIGURE 5-5: RS422 FULL DUPLEX POINT TO POINT CONFIGURATION.....	22
FIGURE 5-6: RS485 FULL DUPLEX POINT TO POINT CONFIGURATION.....	22
FIGURE 5-7: RS485 HALF DUPLEX POINT TO POINT CONFIGURATION	23
FIGURE 5-8: RS485 FULL DUPLEX MULTI-POINT CONFIGURATION.....	23
FIGURE 5-9: RS485 HALF DUPLEX MULTI-POINT CONFIGURATION	24
FIGURE 5-10: I/O BLOCK DIAGRAM.....	25
FIGURE 7-1 : I/O CONNECTOR PINOUT	28

List of Tables

TABLE 2-1 : TECHNICAL SPECIFICATION.....	7
TABLE 3-1 : XR17D154 LOCAL SPACE CONFIGURATION.....	8
TABLE 3-2 : DEVICE CONFIGURATION SPACE.....	8
TABLE 3-3 : UART REGISTER SET OFFSET	9
TABLE 3-4 : UART REGISTER SET	9
TABLE 3-5 : DEVICE CONFIGURATION REGISTERS	10
TABLE 3-6 : UART CHANNEL CONFIGURATION REGISTERS.....	11
TABLE 4-1 : PCI HEADER.....	13
TABLE 4-2 : CONFIGURATION EEPROM TPMC467-XX.....	14
TABLE 4-3 : PHYSICAL CONFIGURATION EEPROM DATA	15
TABLE 5-1 : CPLD REGISTER ADDRESS MAP.....	16
TABLE 5-2 : CHANNEL CONTROL REGISTER.....	17
TABLE 5-3 : MPIO PINS	17
TABLE 5-4 : MPIO DEVICE CONFIGURATION REGISTERS.....	18
TABLE 5-5 : SERIAL CHANNEL SETUP.....	21
TABLE 6-1 : UART BAUD RATE PROGRAMMING	26
TABLE 7-1 : PIN ASSIGNMENT RJ45 FRONT PANEL I/O CONNECTOR	28
TABLE 7-2 : PIN ASSIGNMENT RJ45 FRONT PANEL I/O CONNECTOR.....	28
TABLE 7-3 : SERIAL CHANNEL TO FRONT PANEL PORT MAPPING.....	29

1 Product Description

The TPMC467 is a standard single-width 32 bit PMC module and offers 4 channels of high performance RS232/RS422/RS485 programmable serial interface. The module offers front panel I/O with four RJ45 type connectors. The TPMC467-10 provides a RJ45 I/O pinout according to EIA-232D. The TPMC467-11 provides a non standard RJ45 I/O pinout (as used on Motorola CPU boards).

The serial channels can be individually programmed to operate as RS232, RS422 or RS485 full duplex/half duplex interface. In addition programmable termination is provided for the RS422/RS485 interfaces. After power-up all serial I/O lines are in a high impedance state.

Each RS232 channel supports RxD, TxD, RTS, CTS and GND. RS422 and RS485 full duplex support a four wire interface (RX+, RX-, TX+, TX-) plus ground (GND). RS485 half duplex supports a two wire interface (DX+, DX-) plus ground (GND).

Each channel has 64 byte transmit and receive FIFOs to significantly reduce the overhead required to provide data to and get data from the transmitters and receivers. The FIFO trigger levels are programmable and the baud rate is individually programmable up to 921.6 kbps for RS232 channels and 5.5296 Mbps for RS422 channels. The UART offers readable FIFO levels.

All channels generate interrupts on PCI interrupt INTA. For fast interrupt source detection the UART provides a special Global Interrupt Source Register.

All serial channels use ESD protected transceivers. ESD protection is up to $\pm 15\text{KV}$.

The TPMC467 can operate with 3.3V and 5.0V PCI I/O signaling voltage.

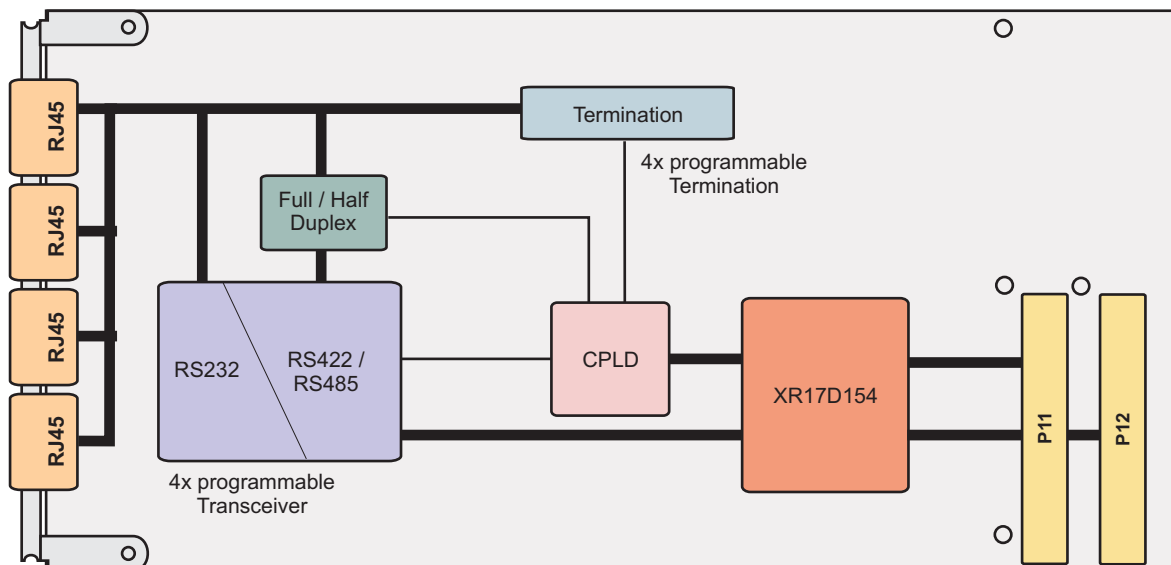

Figure 1-1 : Block Diagram

2 Technical Specification

PMC Interface	
Mechanical Interface	PCI Mezzanine Card (PMC) Interface Single Size
Electrical Interface	PCI Rev. 2.3 compliant 33 MHz / 32 bit PCI 3.3V and 5V PCI Signaling Voltage
On Board Devices	
PCI Target Chip	XR17D154 (Exar)
Quad UART	XR17D154 (Exar)
Transceiver	MAX3161E
I/O Interface	
Interface Type	Asynchronous serial interface
Number of Channels	4
Physical Interface	Software selectable RS232, RS422, RS485 full duplex, RS485 half duplex
Serial Channel I/O Signals	RS232: TxD, RxD, RTS, CTS, GND RS422/RS485 Full Duplex: TxD+/-, RxD+/-, GND RS485 Half Duplex: Dx+/-, GND
Termination	Software selectable 120Ω
Programmable Baud Rates	RS232: up to 921.6 kbps RS422: up to 5.5296 Mbps
ESD Protection	±15kV - Human Body Model
I/O Connector	4x RJ45 Modular Jack (AMP 406 732-1)
Front I/O Pinout	RS232 (TPMC467-10): Compliant to TIA/EIA-561 (EIA-232D) RS232 (TPMC467-11): Compliant to TIP866-TM-20 RS422 (TPMC467-11): Compliant to TIP866-TM-20
Physical Data	
Power Requirements	40 mA typical @ +5V DC (Shutdown, no load) 45 mA typical @ +5V DC (RS232, no load) 75 mA typical @ +5V DC (RS422, no load) 235 mA typical @ +5V DC (RS485 FD Master, no load) 210 mA typical @ +5V DC (RS485 HD, no load) 25 mA typical @ +3.3V DC (no load)
Temperature Range	Operating -40°C to +85°C Storage -55°C to +125°C
MTBF	TPMC467-10: 360 000 h TPMC467-11: 360 000 h
Humidity	5 – 95 % non-condensing
Weight	69 g

Table 2-1 : Technical Specification

3 Local Space Addressing

3.1 XR17D154 Local Space Configuration

The local on board addressable regions are accessed from the PCI side by using the XR17D154 local space.

XR17D154 PCI Base Address (Offset in PCI Configuration Space)	PCI Space Mapping	Size (Byte)	Port Width (Bit)	Endian Mode	Description
0 (0x10)	MEM	2048	32	BIG	Device Configuration Space

Table 3-1 : XR17D154 Local Space Configuration

3.2 Device Configuration Space

PCI Base Address: XR17D154 PCI Base Address 0 (Offset 0x10 in PCI Configuration Space).

The TPMC467 uses the Exar XR17D154 Quad UART to provide and control the 4 channels.

Device Configuration Space Content	PCI Address	Size (Bit)
UART 0 Register Set	PCI Base Address 0 + (0x0000 to 0x007F)	32
Device Configuration Registers	PCI Base Address 0 + (0x0080 to 0x009F)	32
UART 0 Register Set	PCI Base Address 0 + (0x0100 to 0x01FF)	32
UART 1 Register Set	PCI Base Address 0 + (0x0200 to 0x03FF)	32
UART 2 Register Set	PCI Base Address 0 + (0x0400 to 0x05FF)	32
UART 3 Register Set	PCI Base Address 0 + (0x0600 to 0x07FF)	32

Table 3-2 : Device Configuration Space

All registers can be accessed in 8, 16 or 32 bit width with exception to one special case: When reading the receive data together with its LSR register content, the host must read them in 16 or 32 bits format in order to maintain integrity of the data byte with its associated error flags.

3.2.1 UART Register Sets

The Device Configuration Space provides a register set for each of the 4 UARTs.

UART Register Set	Register Set Offset
Serial Channel 0	0x0000
Serial Channel 1	0x0200
Serial Channel 2	0x0400
Serial Channel 3	0x0600

Table 3-3 : UART Register Set Offset

Offset Address	Description	Access	Data Width
0x000 – 0x00F	UART Channel Configuration Registers First 8 registers are 16550 compatible	R/W	8, 16, 32
0x010 – 0x07F	Reserved	-	-
0x080 – 0x093	Channel 0: Device Configuration Registers All other channels: Reserved	R/W	8, 16, 32
0x094 – 0x0FF	Reserved	-	-
0x100	Read FIFO – 64 bytes of RX FIFO data	R	8, 16, 32
	Write FIFO – 64 bytes of TX FIFO data	W	8, 16, 32
0x140 – 0x17F	Reserved	-	-
0x180 – 0x1FF	Read FIFO with errors – 64 bytes of RX FIFO data + LSR	R	16, 32

Table 3-4 : UART Register Set

3.2.2 Device Configuration Registers

The Device Configuration Registers control general operating conditions and monitor the status of various functions. This includes a 16 bit general purpose counter, multipurpose input/outputs (not supported by the TPMC467), sleep mode, soft-reset and device identification, and revision. They are embedded inside the UART 0 Register Set.

Address	Register	Description	Access	Reset Value
0x080	INT0 [7:0]	Channel Interrupt Indicator	R	0x00
0x081	INT1 [15:8]	Interrupt Source Details	R	0x00
0x082	INT2 [23:16]		R	0x00
0x083	INT3 [31:24]		R	0x00
0x084	TIMERCNTL	Timer Control Register	R/W	0x00
0x085	TIMER	Reserved	-	0x00
0x086	TIMERLSB	Programmable Timer Value	R/W	0x00
0x087	TIMERMSB		R/W	0x00
0x088	8XMODE	Sampling Rate Select	R/W	0x00
0x089	REGA	Reserved	-	0x00
0x08A	RESET	UART Reset	W	0x00
0x08B	SLEEP	UART Sleep Mode Enable	R/W	0x00
0x08C	DREV	Device Revision	R	0x01
0x08D	DVID	Device Identification	R	0x28
0x08E	REGB	Simultaneous UART Write & EEPROM Interface	W	0x00
0x08F	MPIOINT	MPIO Interrupt Mask	R/W	0x00
0x090	MPIOLVL	MPIO Level Control	R/W	0x00
0x091	MPIO3T	MPIO Output Pin Tri-state Control	R/W	0x00
0x092	MPIOINV	MPIO Input Polarity Select	R/W	0x00
0x093	MPIOSEL	MPIO Input/Output Select	R/W	0xFF

Table 3-5 : Device Configuration Registers

For a detailed description of the Device Configuration Registers please refer to the XR17D154 data sheet which is available on the Exar website (www.exar.com). The XR17D154 data sheet is also part of the TPMC467-ED Engineering Documentation.

3.2.3 UART Channel Configuration Registers

Each UART channel has its own set of internal UART configuration registers for its own operation control and status reporting. The following table provides the register offsets within a register set, access types and access control:

Register Offset	Comment	Register	Access	Reset Value
16550 Compatible				
0x00	LCR[7] = 0	RHR – Receive Holding Register	R	0xXX
		THR – Transmit Holding Register	W	
	LCR[7] = 1	DLL – Baud Rate Generator Divisor Latch Low	R/W	0xXX
0x01	LCR[7] = 0	IER – Interrupt Enable Register	R/W	0x00
	LCR[7] = 1	DLM – Baud Rate Generator Divisor Latch High	R/W	0xXX
0x02		ISR – Interrupt Status Register	R	0x01
		FCR – FIFO Control Register	W	0x00
0x03		LCR – Line Control Register	R/W	0x00
0x04		MCR – Modem Control Register	R/W	0x00
0x05		LSR – Line Status Register	R	0x60
		Reserved	W	
0x06		MSR – Modem Status Register	R	0xX0
		– Auto RS485 Delay (not supported by the TPMC467)	W	
0x07	User Data	SPR – Scratch Pad Register	R/W	0xFF
Enhanced Registers				
0x08		FCTR – Feature Control Register	R/W	0x00
0x09		EFR – Enhanced Function Register	R/W	0x00
0x0A		TXCNT – Transmit FIFO Level Counter	R	0x00
		TXTRG – Transmit FIFO Trigger Level	W	
0x0B		RXCNT – Receiver FIFO Level Counter	R	0x00
		RXTRG – Receiver FIFO Trigger Level	W	
0x0C		Xchar – Xon, Xoff Received Flags	R	0x00
		Xoff-1 – Xoff Character 1	W	
0x0D		Reserved	R	0x00
		Xoff-2 – Xoff Character 2	W	
0x0E		Reserved	R	0x00
		Xon-1 – Xon Character 1	W	
0x0F		Reserved	R	0x00
		Xon-2 – Xon Character 2	W	

Table 3-6 : UART Channel Configuration Registers

The address for a UART Channel Configuration Register *x* in a UART Register Set for channel *y* is:

PCI Base Address 0 (PCI Base Address for the UART Register Space)

+ UART Register Set Offset for *channel y*

+ Register Offset for *register x*

Addressing example:

The address for the LCR register of UART channel 2 is:

PCI Base Address (PCI Base Address for the Device Configuration Space)

+ 0x0400 (Offset of the UART register set for serial channel 2)

+ 0x0003 (Offset of the LCR register within a UART register set)

For a detailed description of the serial channel registers please refer to the XR17D154 data sheet which is available on the Exar website (www.exar.com). The XR17D154 data sheet is also part of the TPMC467-ED Engineering Documentation.

4 XR17D154 Target Chip

4.1 PCI Configuration Registers (PCR)

PCI CFG Register Address	Write '0' to all unused (Reserved) bits							PCI writeable	Initial Values (Hex Values)	
	31	24	23	16	15	8	7			0
0x00	Device ID				Vendor ID				N	01D3 1498
0x04	Status				Command				Y	0080 0000
0x08	Class Code					Revision ID		N	070002 ??	
0x0C	BIST	Header Type		PCI Latency Timer		Cache Line Size		N	00 00 00 00	
0x10	Memory Base Address Register (BAR)							Y	FFFFFF00	
0x14	I/O Base Address Register (Unimplemented)							N	00000000	
0x18	Base Address Register 0 (Unimplemented)							N	00000000	
0x1C	Base Address Register 1 (Unimplemented)							N	00000000	
0x20	Base Address Register 2 (Unimplemented)							N	00000000	
0x24	Base Address Register 3 (Unimplemented)							N	00000000	
0x28	Reserved							N	00000000	
0x2C	Subsystem ID			Subsystem Vendor ID				N	s.b. 1498	
0x30	Expansion ROM Base Address (Unimplemented)							N	00000000	
0x34	Reserved							N	00000000	
0x38	Reserved							N	00000000	
0x3C	Max_Lat	Min_Gnt	Interrupt Pin		Interrupt Line		Y[7:0]	00 00 01 00		

Table 4-1 : PCI Header

Device-ID: 0x01D3 TPMC467
 Vendor-ID: 0x1498 TEWS TECHNOLOGIES
 Revision ID: XR17D154 silicon revision
 Subsystem-ID: 0x000A -10
 0x000B -11
 Subsystem Vendor-ID: 0x1498 TEWS TECHNOLOGIES

4.2 Configuration EEPROM

After power-on or PCI reset, the XR17D154 loads initial configuration register data from the on board configuration EEPROM.

The configuration EEPROM contains the following configuration data:

- Vendor ID
- Vendor Device ID
- SubSystem Vendor ID
- SubSystem Device ID

See the XR17D154 Manual for more information.

Address	Configuration Register	Configuration Register Offset	Value
0x00	Vendor ID	0x02	0x1498
0x01	Device ID	0x00	0x01D3
0x02	Subsystem Vendor ID	0x2E	0x1498
0x03	Subsystem ID	0x2C	s.b.

Table 4-2 : Configuration EEPROM TPMC467-xx

Subsystem-ID Value (Offset 0x0C): TPMC467-10 0x000A
 TPMC467-11 0x000B

The words following the configuration data contain:

- The module version and revision
- The UART clock frequency in Hz
- The physical interface attached to the serial channels
- The maximal baud rate of the transceivers in bps
- The supported control signals of the serial channels

For the physical interfaces and the control signals applies: Bit 3 represents UART channel 3 and bit 0 represents UART channel 0. The appropriate bit is set to '1' for each UART channel attached to the physical interface represented by the word. Bit 15 to bit 4 are always '0'.

Address	Configuration Register	TPMC467-10	TPMC467-11
0x04	Module Version	0x0100	0x0100
0x05	Module Revision	0x0000	0x0000
0x06	EEPROM Revision	0x0002	0x0002
0x07	Oscillator Frequency (high)	0x02A3	0x02A3
0x08	Oscillator Frequency (low)	0x0000	0x0000
0x09-0x0F	Reserved	-	-
0x10	RS232 Channels	0x000F	0x000F
0x11	RS422 Channels	0x000F	0x000F
0x12	TTL Channels	0x0000	0x0000
0x13	RS485 Full Duplex Channels	0x000F	0x000F
0x14	RS485 Half Duplex Channels	0x000F	0x000F
0x15-0x1E	Reserved	-	-
0x1F	Programmable Interfaces	0x000F	0x000F
0x20	Max Data Rate RS232 (high)	0x000F	0x000F
0x21	Max Data Rate RS232 (low)	0x4240	0x4240
0x22	Max Data Rate RS422 (high)	0x0098	0x0098
0x23	Max Data Rate RS422 (low)	0x9680	0x9680
0x24	Max Data Rate TTL (high)	0x0000	0x0000
0x25	Max Data Rate TTL (low)	0x0000	0x0000
0x26	Max Data Rate RS485 Full Duplex (high)	0x0098	0x0098
0x27	Max Data Rate RS485 Full Duplex (low)	0x9680	0x9680
0x28	Max Data Rate RS485 Half Duplex (high)	0x0098	0x0098
0x29	Max Data Rate RS485 Half Duplex (low)	0x9680	0x9680
0x2A-0x2F	Reserved	-	-
0x30	RxD & TxD	0x000F	0x000F
0x31	RTS & CTS	0x0000	0x0000
0x32	Full modem	0x0000	0x0000
0x33-0x37	Reserved	-	-
0x38	Enhanced RTS & CTS (Front or Back I/O only)	0x0000	0x0000
0x39	Enhanced Full modem (Front or Back I/O only)	0x0000	0x0000
0x3A	Channels with enhanced RTS & CTS Support for RS232 only	0x000F	0x000F
0x3B-0x3F	Reserved	-	-

Table 4-3 : Physical Configuration EEPROM Data

5 Configuration Hints

The TPMC467 physical interfaces of the serial channels are individually software programmable to various interface configurations. For this purpose a CPLD provides a control register for each interface channel.

5.1 CPLD Description

The CPLD provides a Channel Control Register for each of the interface channels. Each of the Channel Control Registers is individually addressable. The access to this registers is described in detail in chapter "5.2 CPLD Access".

5.1.1 CPLD Address Map

Refer to the following chart for the register addresses.

Address	Register Name	Size (Bit)
000	Control Register Channel 0	7
001	Control Register Channel 1	7
010	Control Register Channel 2	7
011	Control Register Channel 3	7

Table 5-1 : CPLD Register Address Map

5.1.2 Channel Control Register

This register is identical for all channels.

Bit	Symbol	Description	Access	Reset Value
6	SHDN	Active-Low Shutdown-Control. Drive SHDN high to shut down transmitters and charge pump. '0': Normal operation '1': Shutdown	R/W	1
5	SLEW LIMIT	Transmitter Speed-Select. Select slew-rate limiting for RS232 and RS485. Slew-rate limits with a logic-level high. '0': Normal data rate limit (RS232: 1 Mbps; RS485: 10 Mbps) '1': Limit data rate to 250 kbps (both RS232 & RS485)	R/W	0
4	TTERM	Transmitter Termination Enable Terminate transmit line with a 120Ω termination resistor '0': Termination inactive '1': Termination active	R/W	0
3	RTERM	Receiver Termination Enable Terminate receive line with a 120Ω termination resistor '0': Termination inactive '1': Termination active	R/W	0

Bit	Symbol	Description	Access	Reset Value
2	RENA	Auto RS485 Receiver Enable When the Auto RTS Control feature of the XR17D154 is used in half duplex configurations, this bit can be used to inhibit the reception of an echo of the own data transmission '0': Normal operation (receiver is always enabled) '1': Inhibit echo reception (receiver is disabled during data transmission)	R/W	0
1	HDPLX	Selectable Mode Functionality. Operates in full-duplex mode when low; operates in half-duplex mode when high. '0': Full-duplex '1': Half-Duplex	R/W	0
0	RS485/ RS232#	Selectable Mode Functionality. Operates as RS485 with a logic-level high; operates as RS232 with a logic-level low. '0': RS232 '1': RS485	R/W	0

Table 5-2 : Channel Control Register

5.2 CPLD Access

The CPLD is connected to the MPIO-pins of the XR17D154 to provide access to the control registers.

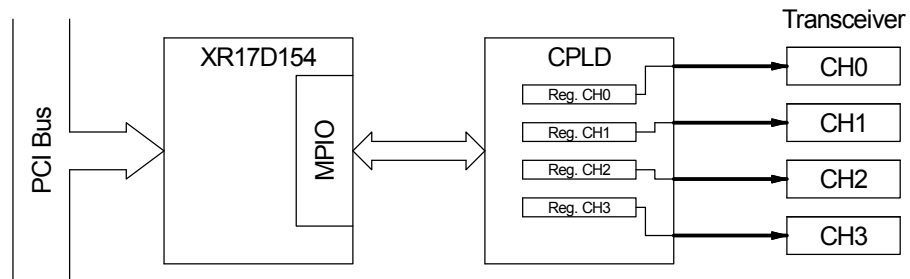

Figure 5-1 : CPLD-Bus Block Diagram

The MPIO-pins form a simple bus to the CPLD. The following chart gives an overview about the MPIO pin assignment:

MPIO Pin	Direction	Function
MPIO[0]	Output	CEN – Chip Enable
MPIO[1]	Output	R/W# - Read/Write Low: Write to Address High: Read from Address
MPIO[2]	Output	CLK – Clock
MPIO[5-3]	Output	ADR – Register Address
MPIO[6]	Output	DATAOUT – Serial Data Output
MPIO[7]	Input	DATAIN – Serial Data Input

Table 5-3 : MPIO Pins

5.2.1 Accessing XR17D154 MPIO-Pins

The MPIO Registers are accessible at PCI Base Address 0 + Device Configuration Register Offset.

Address Offset	Register	Description	Access	Reset Value
0x08F	MPIOINT	MPIO Interrupt Mask	R/W	0x00
0x090	MPIOLVL	MPIO Level Control	R/W	0x00
0x091	MPIO3T	MPIO Output Pin Tri-state Control	R/W	0x00
0x092	MPIOINV	MPIO Input Polarity Select	R/W	0x00
0x093	MPIOSEL	MPIO Input/Output Select	R/W	0xFF

Table 5-4 : MPIO Device Configuration Registers

MPIOINT, MPIOLVL and MPIO3T must be left at their default values. MPIOSEL must be set to 0x80 to configure MPIO[6-0] pins as outputs and MPIO[7] as input. MPIOLVL sets the output level of the MPIO output pins and is used to write on the CPLD-bus.

5.2.2 CPLD-Bus Protocol

5.2.2.1 Write

A CPLD register write access starts with setting CEN to '1'. This resets the CPLD's internal state-machine. Before the first clock pulse is issued, ADR and DATAOUT have to be set; R/W# must be left '0'. The first rising edge of CLK samples the ADR bits and the DATAOUT bit. ADR determines which internal register is accessed. The following 6 rising edges of CLK sample the remaining data bits, additional CLK pulses are ignored. Setting CEN back to '0' completes the access and the configuration of the transceivers will be updated.

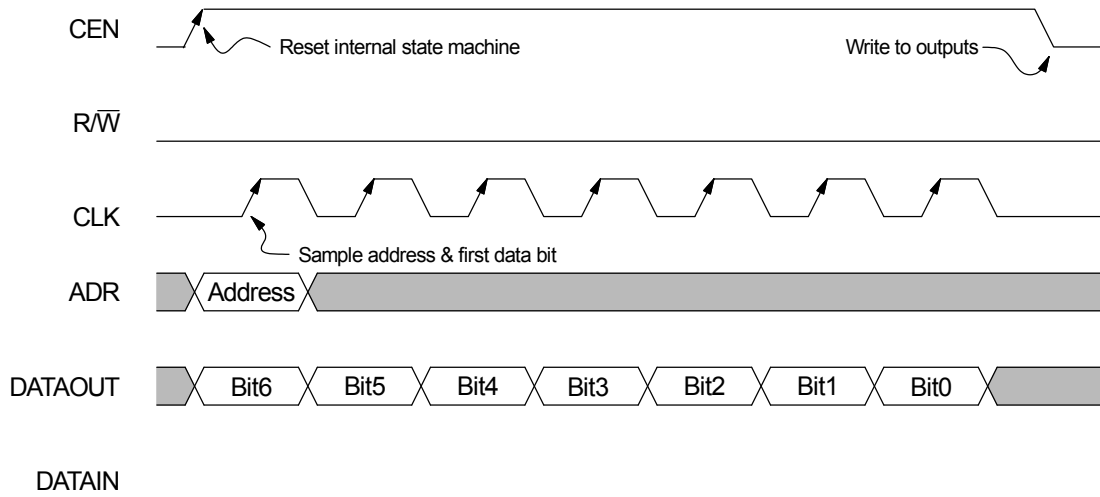

Figure 5-2 : CPLD-Bus Write

Example (pseudocode):

Write value 0x05 to CPLD address 0x03

```
define MPIOLVL 0x90;
define MPIOSEL 0x93;
void Write_XR17D154(int address, int value);
```

```

Write_XR17D154(MPIOSEL, 0x80); // Setting up MPIOSEL

Write_XR17D154(MPIOLVL, 0x19); // CEN = '1', ADR = "011", D(6) = '0'
Write_XR17D154(MPIOLVL, 0x1D); // CLK = '1'
Write_XR17D154(MPIOLVL, 0x01); // CLK = '0', ADR = "000", D(5) = '0'
Write_XR17D154(MPIOLVL, 0x05); // CLK = '1'
Write_XR17D154(MPIOLVL, 0x01); // CLK = '0', D(4) = '0'
Write_XR17D154(MPIOLVL, 0x05); // CLK = '1'
Write_XR17D154(MPIOLVL, 0x01); // CLK = '0', D(3) = '0'
Write_XR17D154(MPIOLVL, 0x05); // CLK = '1'
Write_XR17D154(MPIOLVL, 0x41); // CLK = '0', D(2) = '1'
Write_XR17D154(MPIOLVL, 0x45); // CLK = '1'
Write_XR17D154(MPIOLVL, 0x01); // CLK = '0', D(1) = '0'
Write_XR17D154(MPIOLVL, 0x05); // CLK = '1'
Write_XR17D154(MPIOLVL, 0x41); // CLK = '0', D(0) = '1'
Write_XR17D154(MPIOLVL, 0x45); // CLK = '1'
Write_XR17D154(MPIOLVL, 0x00); // CLK = '0', CEN = '0'

```

5.2.2.2 Read

A CPLD register read access starts with setting CEN to '1'. This resets the CPLD's internal state-machine. Before the first clock pulse is issued, ADR and R/W# have to be set. The first rising edge of CLK samples the ADR bits and starts the output of the first DATAIN bit. ADR determines which internal register is accessed. The following 6 rising edges of CLK put out the remaining data bits, additional CLK pulses are ignored. Setting CEN back to '0' completes the access.

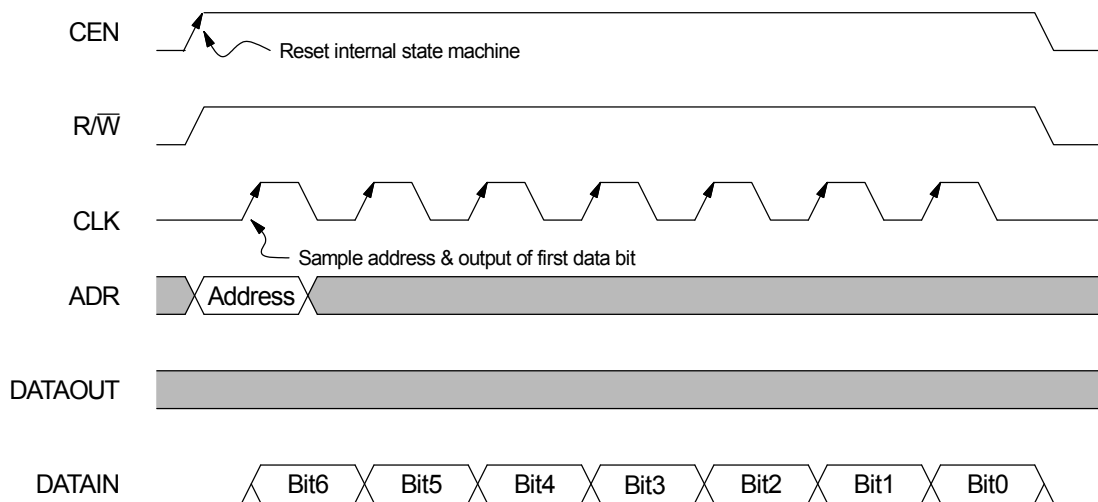

Figure 5-3 : CPLD-Bus Read

Example (pseudocode):

Read value 0x05 to CPLD address 0x03

```

define MPIOLVL 0x90;
define MPIOSEL 0x93;
int Read_XR17D154(int address); // Returns the address' bit 7
int value

Write_XR17D154(MPIOSEL, 0x80); // Setting up MPIOSEL

Write_XR17D154(MPIOLVL, 0x1B); // CEN = '1', ADR = "011", R/W# = '1'
Write_XR17D154(MPIOLVL, 0x1F); // CLK = '1'
Write_XR17D154(MPIOLVL, 0x03); // CLK = '0', ADR = "000"

```

```

value |= (Read_XR17D154(MPIOLVL) << 6); // Read D(6)
Write_XR17D154(MPIOLVL, 0x07); // CLK = '1'
Write_XR17D154(MPIOLVL, 0x03); // CLK = '0'
value |= (Read_XR17D154(MPIOLVL) << 5); // Read D(5)
Write_XR17D154(MPIOLVL, 0x07); // CLK = '1'
Write_XR17D154(MPIOLVL, 0x03); // CLK = '0'
value |= (Read_XR17D154(MPIOLVL) << 4); // Read D(4)
Write_XR17D154(MPIOLVL, 0x07); // CLK = '1'
Write_XR17D154(MPIOLVL, 0x03); // CLK = '0'
value |= (Read_XR17D154(MPIOLVL) << 3); // Read D(3)
Write_XR17D154(MPIOLVL, 0x07); // CLK = '1'
Write_XR17D154(MPIOLVL, 0x03); // CLK = '0'
value |= (Read_XR17D154(MPIOLVL) << 2); // Read D(2)
Write_XR17D154(MPIOLVL, 0x07); // CLK = '1'
Write_XR17D154(MPIOLVL, 0x03); // CLK = '0'
value |= (Read_XR17D154(MPIOLVL) << 1); // Read D(1)
Write_XR17D154(MPIOLVL, 0x07); // CLK = '1'
Write_XR17D154(MPIOLVL, 0x03); // CLK = '0'
value |= (Read_XR17D154(MPIOLVL) << 0); // Read D(0)
Write_XR17D154(MPIOLVL, 0x00); // CEN = '0', R/W# = '0'

```

5.3 Serial Interface Channel Setup

After power-up all transceivers are in shutdown mode, i.e. the outputs are in tri-state mode. Therefore the serial interfaces must be properly set up before they can be used.

The interfaces can be programmed to following Modes:

- RS232
- RS485/RS422 full-duplex (with optional termination)
- RS485 half-duplex (Master/Slave, with optional termination)

5.3.1 Special Features

5.3.1.1 Auto RS485 Operation

In RS485 half duplex applications it is necessary to tristate the driver when it is not active. The XR17D154 provides a special function, the “Auto RS485 Operation” for this purpose. The UART’s RTS signal is connected to the driver enable pin of the transceiver. The UART asserts RTS to enable the driver before it starts to send a character and deasserts the RTS signal after a programmable delay after the stop bit of the last transmitted character. The delay optimizes the time needed for the last transmission to reach the farthest station on a long cable network before switching off the line driver.

The Auto RS485 Operation is enabled by FCTR bit 5. The delay is specified in MSR[7:4]

5.3.1.2 RS485 Receiver Control

In RS485 half duplex applications the driver and receiver are connected with each other. To prevent the echo of local data, the receive line can be inhibited for the time the driver is enabled. This is done by activating the “Auto RS485 Receiver Enable” in the Channel Control Register.

When the Auto RS485 Receiver Enable is not activated in a half duplex application, this will result in a kind of loopback mode. This may be done on purpose to monitor the loopback data for errors which

would indicate a line contention. When the channel is unconnected, this may also be used as a build in self test.

5.3.1.3 Slew Rate Limiting

The SLEW LIMIT control is used to select the slew-rate limiting of the RS232 transmitters and the RS485/RS422 drivers. With SLEW LIMIT asserted, the RS232 transmitters and the RS485/RS422 driver are slew-rate limited to reduce EMI, resulting in a max data rate of 250 kbps. RS232 data rates up to 1 Mbps and RS485/RS422 data rates up to 10 Mbps are possible when SLEW LIMIT is unasserted. SLEW LIMIT can be changed during operation without interrupting data communications.

5.3.1.4 Low-Power Shutdown

The MAX3161E has a shutdown control input, SHDN. When SHDN is ON, the charge pump and transmitters are shut down and supply current is reduced to 10nA. The RS232 receiver outputs remain active if in RS232 mode. The charge-pump capacitors must be recharged when coming out of shutdown before resuming operation in either RS232 or RS485/RS422 mode.

5.3.2 Channel Setup

Each interface channel must be set up in its associated Channel Control Register in the CPLD. Depending on the interface configuration the “Auto RS485 Operation” must be activated in the Feature Control Register in the XR17D154. Refer to the next chapter “RS485/RS422 Configuration Examples” to find out which interface configurations suits your needs.

The following table shows how to program the interfaces to the commonly used modes:

Bit	Symbol	Reset Value	RS232	RS422 Multidrop	RS422 FD	RS485 FD (Master)	RS485 FD Slave	RS485 HD
	CPLD	Channel Control Register						
0	RS485/RS232#	OFF	OFF	ON	ON	ON	ON	ON
1	HDPLX	OFF	OFF	OFF	OFF	OFF	OFF	ON
2	RENA	OFF	OFF	OFF	OFF	OFF	OFF	ON
3	RTERM	OFF	OFF (1)	ON (2)	ON	ON	ON (2)	OFF
4	TTERM	OFF	OFF (1)	OFF	OFF	ON	ON (2)	ON (2)
5	SLEW LIMIT	OFF	User	User	User	User	User	User
6	SHDN	ON	OFF	OFF	OFF	OFF	OFF	OFF
	XR17D154	Feature Control Register (FCTR)						
5	Auto RS485 Operation	OFF	OFF	OFF	OFF	OFF	ON	ON

(1) RTERM / TTERM settings are ignored in RS232 mode.

(2) Depends on bus configuration. Terminate only if the transceiver is the end-point of the bus.

Table 5-5 : Serial Channel Setup

5.4 RS485/RS422 Configuration Examples

5.4.1 RS422 Multidrop

RS485	HDPLX	RENA	RTERM	TTERM	FCTR[5]
ON	OFF	OFF	ON*	OFF	OFF

* Terminate only if the device is a receiver and the end-point of the bus.

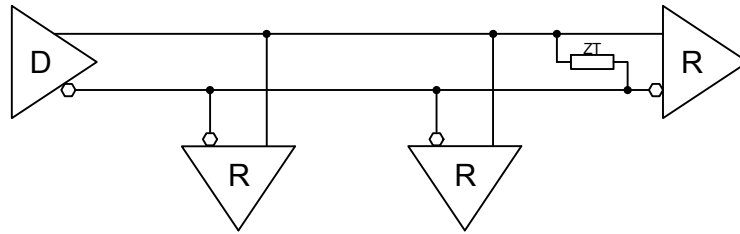

Figure 5-4 : RS422 Multidrop Configuration

5.4.2 RS422 Full Duplex Point to Point

RS485	HDPLX	RENA	RTERM	TTERM	FCTR[5]
ON	OFF	OFF	ON	OFF	OFF

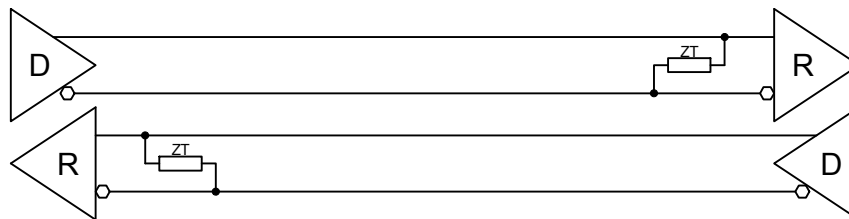

Figure 5-5: RS422 Full Duplex Point to Point Configuration

5.4.3 RS485 Full Duplex Point to Point

RS485	HDPLX	RENA	RTERM	TTERM	FCTR[5]
ON	OFF	OFF	ON	ON	OFF



Figure 5-6: RS485 Full Duplex Point to Point Configuration

5.4.4 RS485 Half Duplex Point to Point

RS485	HDPLX	RENA	RTERM	TTERM	FCTR[5]
ON	ON	ON	OFF	ON	ON

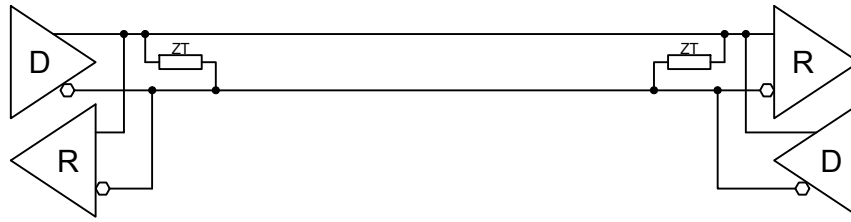

Figure 5-7: RS485 Half Duplex Point to Point Configuration

5.4.5 RS485 Full Duplex Multi-point

Also referred to as “party-line”

Master

RS485	HDPLX	RENA	RTERM	TTERM	FCTR[5]
ON	OFF	OFF	ON	ON	OFF

Slave

RS485	HDPLX	RENA	RTERM	TTERM	FCTR[5]
ON	OFF	OFF	ON*	ON*	ON

* Terminate only if the device is the end-point of the bus.

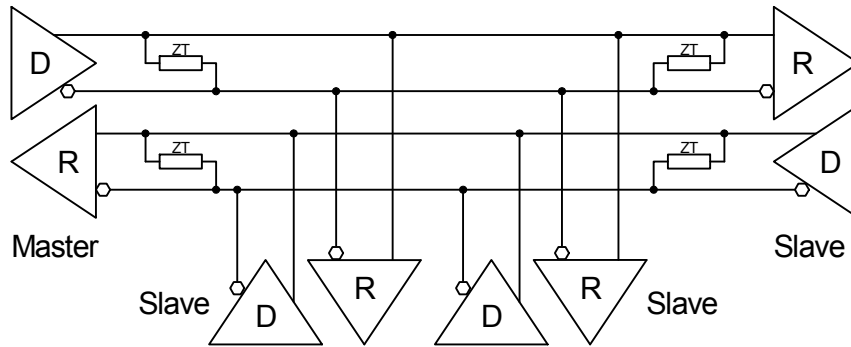

Figure 5-8: RS485 Full Duplex Multi-Point Configuration

5.4.6 RS485 Half Duplex Multi-point

Also referred to as “party-line”

RS485	HDPLX	RENA	RTERM	TTERM	FCTR[5]
ON	ON	ON	OFF	ON*	ON

* Terminate only if the device is the end-point of the bus.

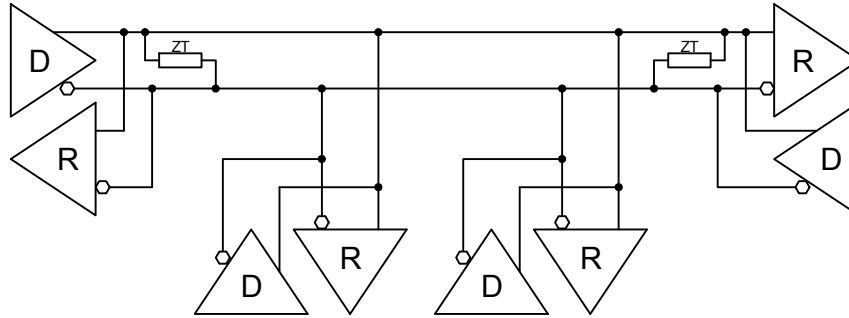

Figure 5-9: RS485 Half Duplex Multi-Point Configuration

5.5 I/O Electrical Interface

5.5.1 ±15kV ESD Protection

The receiver inputs and transmitter outputs are characterized for ±15kV ESD protection using the Human Body Model.

5.5.2 RS232 Transceivers

The RS232 transmitters are inverting-level translators that convert CMOS-logic levels to ±5V EIA/TIA-232-compliant levels. The transmitters are guaranteed at a 250 kbps data rate in slew-rate limited mode with worst-case loads of 3kΩ in parallel with 1000pF. Data rates up to 1 Mbps can be achieved by not asserting SLEW LIMIT. When powered down or in shutdown, the outputs are high impedance and can be driven to ±13.2V.

The receivers convert RS232 signals to CMOS-logic output levels. All receivers have inverting outputs that remain active in shutdown. The MAX3161E permit their receiver inputs to be driven to ±25V. Floating receiver input signals are pulled to ground through internal 5kΩ resistors, forcing the outputs to a logic-high.

5.5.3 RS485/RS422 Transceivers

The RS485/RS422 transceivers feature fail-safe circuitry that guarantees a logic-high receiver output when the receiver inputs are open or shorted, or when they are connected to a terminated transmission line with all drivers disabled. They also feature selectable reduced slew-rate drivers that minimize EMI and reduce reflections caused by improperly terminated cables, allowing error-free data transmission up to 250 kbps. The transmitters can operate at speeds up to 10 Mbps with the slew-rate limiting disabled. Drivers are short-circuit current limited and thermally limited to protect them against excessive power dissipation. Half-duplex communication is enabled by driving HDPLX high.

5.5.4 Termination

The receive and the transmit line can be terminated with a 120Ω termination resistor. The termination is software selectable.

5.6 Block Diagram

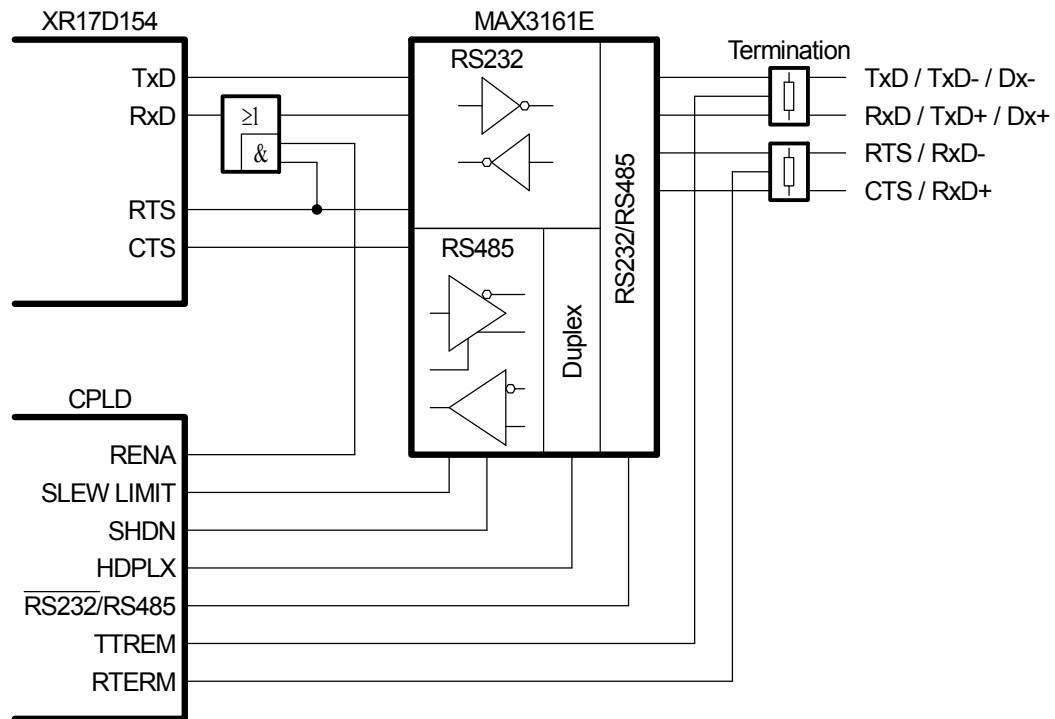

Figure 5-10: I/O Block Diagram

6 Programming Hints

6.1 UART Baud Rate Programming

Each of the 4 UART channels of the TPMC467 provides a programmable Baud Rate Generator. The clock of the XR17D154 UART can be divided by any divisor from 1 to $2^{16} - 1$. The divisor can be programmed by the UART channel DLM (Divisor MSB) and DLL (Divisor LSB) registers. After a reset bit 7 of the UART channels MCR register defaults to '0' and the divisor value is 0xFFFF.

The basic formula of baud rate programming is:

$$\text{Baud Rate} = \frac{44.2368\text{MHz}}{16 \cdot \text{Divisor} \cdot (1 + 3 \cdot \text{MCR}[7])}$$

Examples for standard baud rates are given in following chart:

Baud Rate MCR[7] = 0	Baud Rate MCR[7] = 1	Divisor	DLM Value	DLL Value
400	100	0x1B00	0x1B	0x00
600	150	0x1200	0x12	0x00
1200	300	0x0900	0x09	0x00
2400	600	0x0480	0x04	0x80
4800	1200	0x0240	0x02	0x40
9600	2400	0x0120	0x01	0x20
19.2k	4800	0x0090	0x00	0x90
38.4k	9600	0x0048	0x00	0x48
57.6k	14.4k	0x0030	0x00	0x30
115.2k	28.8k	0x0018	0x00	0x18
230.4k	57.6k	0x000C	0x00	0x0C
460.8k	115.2k	0x0006	0x00	0x06
921.6k	230.4k	0x0003	0x00	0x03
1382.4k	345.6k	0x0002	0x00	0x02
2764.8k	691.2k	0x0001	0x00	0x01

Table 6-1 : UART Baud Rate Programming

To calculate a divisor value for a given baud rate, use following formula:

$$\text{Divisor} = \frac{44.2368\text{MHz}}{16 \cdot \text{Baud Rate} \cdot (1 + 3 \cdot \text{MCR}[7])}$$

The sampling rate for a UART channel can be set to 8x (normal operation is 16x) in the 8XMODE register. Transmit and receive data rates will double by selecting 8x sample rate.

The maximum achievable baud rate is 5.5296 Mbps (Divisor = 0x0001 & 8x sampling rate).

These steps should be used to modify the DLM, DLL registers of an UART channel:

1. Write 0x80 to the LCR register of the UART channel (enable access to the DLM, DLL registers).
2. Program the DLM, DLL registers of the UART channel.
3. Write normal operation byte value to the LCR register of the UART channel.

These steps should be used to modify MCR register bit 7 of an UART channel (set baud rate generator prescaler):

1. Set UART channel EFR register bit 4 to '1' (enable modification of MCR register bits 5-7).
2. Modify UART channel MCR register bit 7.
3. Set UART channel EFR register bit 4 to '0' (latch modified MCR register setting).

Note that the maximum baud rate for RS232 channel is 921.6 kps. Thus the minimum divisor value for RS232 channels is 0x0003 with MCR[7] = 0.

7 Pin Assignment – I/O Connector

The TPMC467 front panel I/O connector is a RJ45 modular jack connector (e.g. AMP# 406 732-1).

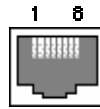

Figure 7-1 : I/O Connector Pinout

7.1 Front Panel I/O Connector (TPMC467-10)

Pin	Signal RS232	Signal RS422
1	-	-
2	-	-
3	-	TxD+
4	GND	GND
5	RxD	+5V Termination Supply (unfused)
6	TxD	TxD-
7	CTS	RxD+
8	RTS	RxD-

Table 7-1 : Pin Assignment RJ45 Front Panel I/O Connector

The RS232 pinout is compliant to TIA/EIA-561 (EIA-232D).

7.2 Front Panel I/O Connector (TPMC467-11)

Pin	Signal RS232	Signal RS422
1	-	-
2	RTS	TxD+
3	GND	GND
4	TxD	TxD-
5	RxD	RxD-
6	GND	GND
7	CTS	RxD+
8	-	-

Table 7-2 : Pin Assignment RJ45 Front Panel I/O Connector

The RS232 pinout is compliant to TIP866-TM-20 or to the “Motorola Standard”. The RS422 pinout is compliant to TIP866-TM-20.

7.3 Serial Channel to Front Panel Port Mapping

The serial channels 0-3 are mapped onto the 4 front panel connectors labeled Port1 – Port4.

Serial Channel	Front Panel Port
Channel 0	Port 1
Channel 1	Port 2
Channel 2	Port 3
Channel 3	Port 4

Table 7-3 : Serial Channel to Front Panel Port Mapping